

Dade-Collier Training and Transition Airport (TNT)



Airport Layout Plans Set Narrative Report

PREPARED FOR:

Miami-Dade Aviation Department

PREPARED BY:

RICONDO & ASSOCIATES, INC.

IN ASSOCIATION WITH:

Jacobsen/Daniels Associates, LLC



RICONDO[®]
& ASSOCIATES

December 2017

Table of Contents

A.	Executive Summary	A-1
B.	Basic Aeronautical Forecasts	B-1
B.1	Total Annual Operations	B-2
B.2	Annual Itinerant Operations by all Aircraft	B-2
B.3	Annual Itinerant Operations by Current Critical Aircraft	B-2
B.4	Annual Itinerant Operations by Future Critical Aircraft	B-3
B.5	Number of Based Aircraft	B-4
B.6	Annual Instrument Approaches	B-4
B.7	Number of Enplanements	B-5
B.8	Critical Aircraft	B-5
B.9	Runway Design Code	B-5
B.10	Runway Reference Codes	B-6
C.	Alternatives/Proposed Development	C-1
C.1	Proposed Development Items	C-1
	C.1.1 AIRFIELD	C-1
	C.1.2 SUPPORT FACILITIES	C-2
C.2	Near-Term and Future Approach Procedures Requirements	C-3
C.3	Navigational Aids	C-4
C.4	Wind Coverage	C-4
D.	Modification to Standards	D-1
E.	Obstruction Surfaces	E-1
F.	Runway Protection Zone	F-1
G.	Development Summary	G-1
G.1	Development Projects Completed Since Last ALP	G-1
G.2	Implementation Plan	G-3
H.	Shadow or Line-of-Sight Study	H-1
I.	Letters of Coordination	I-1
J.	Wildlife Hazard Management	J-1
K.	Preliminary Identification of Environmental Features	K-1
L.	Action Items from Runway Safety Program Office	L-1

M. Declared DistancesM-1

N. Airport Layout Plan Drawings N-1

N.1 Cover Sheet..... N-1

N.2 Data Sheet..... N-1

N.3 Existing and Future Airport Layout Plan..... N-2

N.4 Airport Airspace Plan N-2

N.5 Existing & Future Inner Portion of the Approach Surface Drawings N-4

N.6 Airport Land Use Drawing..... N-5

N.7 Airport Property Map N-5

List of Appendices

Appendix A ALP Checklist – ARP SOP 2.0

Appendix B 2017 Airport Layout Plan Set

Appendix C FAA Approval Letter for MDAD SMP Study GA Forecast Report

List of Tables

Table A-1: Dade-Collier Training and Transition Airport - Runway Characteristics.....A-3

Table A-2: SMP Aviation Forecast Summary -Dade-Collier Training and Transition AirportA-4

Table A-3: Dade-Collier Training and Transition Airport - Preliminary Capital Funding PlanA-5

Table B-1: Dade-Collier Training and Transition Airport - 2014 Critical Aircraft OperationsB-4

Table B-2: Dade-Collier Training and Transition Airport – Runway Design Code.....B-6

Table B-3: Dade-Collier Training and Transition Airport – Approach and Departure Reference Codes.....B-6

Table C-1: Dade-Collier Training and Transition Airport – Tenant/Support Facility NeedsC-3

Table C-2: Dade-Collier Training and Transition Airport – Navigational AidsC-4

Table G-1: Dade-Collier Training and Transition Airport - Engineer’s Estimate of Probable Costs G-1

Table K-1: Summary of Potential Environmental Impacts.....K-2

Table M-1: Dade-Collier Training and Transition Airport – Declared Distance..... M-1

Table N-1: Dade-Collier Training and Transition Airport - CFR Part 77 Approach Surface Characteristics N-4

List of Exhibits

Exhibit A-1: Miami-Dade Airport Location MapA-2

Exhibit B-1: Dade-Collier Training and Transition Airport - Forecasts of General Aviation Aircraft
OperationsB-3

Exhibit C-1: Dade-Collier Training and Transition Airport - Airfield Demand-Capacity ComparisonC-2

Exhibit G-1: Dade-Collier Training and Transition Airport – Recommended Development Scenario..... G-2

Exhibit K-1: Environmental Features - Major Drainage Ditches.....K-3

Exhibit K-2: Environmental Features - WetlandsK-4

Exhibit K-3: Environmental Features – Flood ZonesK-5

Exhibit K-4: Environmental Features – Historical or Cultural ResourcesK-6

Exhibit K-5: Environmental Features – DOT Section 4(f).....K-7

Exhibit K-6: Environmental Features – Flora/FaunaK-8

Exhibit K-7: Environmental Features – Natural ResourcesK-9

A. Executive Summary

In 2008, the Miami-Dade Aviation Department (MDAD) initiated the Miami Dade Strategic Airport Master Plan (SMP), which serves as an update to the airport master plans for Miami International Airport and its four general aviation airports. These general aviation airports comprise of Miami-Opa Locka Executive Airport, Miami Executive Airport, Miami Homestead General Aviation Airport and Dade-Collier Training and Transition Airport. The SMP defines Miami-Dade County's overall approach to serving the long-term capital needs for its system of five airports to continue providing a high level of service for the surrounding communities. In lieu of a comprehensive airport master plan report, MDAD has elected to submit stand-alone Aeronautical Forecast documents and Airport Layout Plan (ALP) packages to the Federal Aviation Administration (FAA) for review and approval. The activity forecasts for the four general aviation airports were formerly approved by the FAA on August 6, 2012.

This document serves as the ALP Narrative Report for the Dade-Collier Training and Transition Airport (TNT or the Airport) that accompanies the ALP package that is reflective of the SMP's final recommendations for the Airport. The proposed development contained on the ALP for TNT would satisfy the Airport's operational demand levels projected through 2035 by the SMP Aeronautical Forecasts. In accordance with the FAA Airports Division's Standard Operating Procedure 2.00 (ARP SOP 2.00), *Standard Procedure for FAA Review and Approval of Airport Layout Plans*, the structure of this ALP Narrative Report is consistent with that of the ALP Review Checklist contained in **Appendix A** of SOP 2.00.

Exhibit A-1 illustrates the location of the five airports operated by MDAD. TNT which was originally designated as the "Everglades Jetport" is located 36 miles west of the Miami central business district within the Florida Everglades. Although the Airport is located within the eastern-most portions of Collier County, it is owned by Miami-Dade County and operated by the Miami-Dade Aviation Department. Once planned to be one of the largest commercial air carrier airports to serve southeast Florida, TNT was envisioned to grow to an eventual six-runway airport that would accommodate modern air carriers and the [then] planned U.S. Supersonic Transport aircraft. Because of environmental concerns, construction was halted after the completion of a single runway. The facility is currently available for use by general aviation users having prior permission and MDAD-issued permit, but is closed from sunset to sunrise. The limited use and role of TNT and its ability to attract and/or accommodate or generate additional aviation activity is not anticipated to change in the foreseeable future.

Exhibit A-1: Miami-Dade Airport Location Map

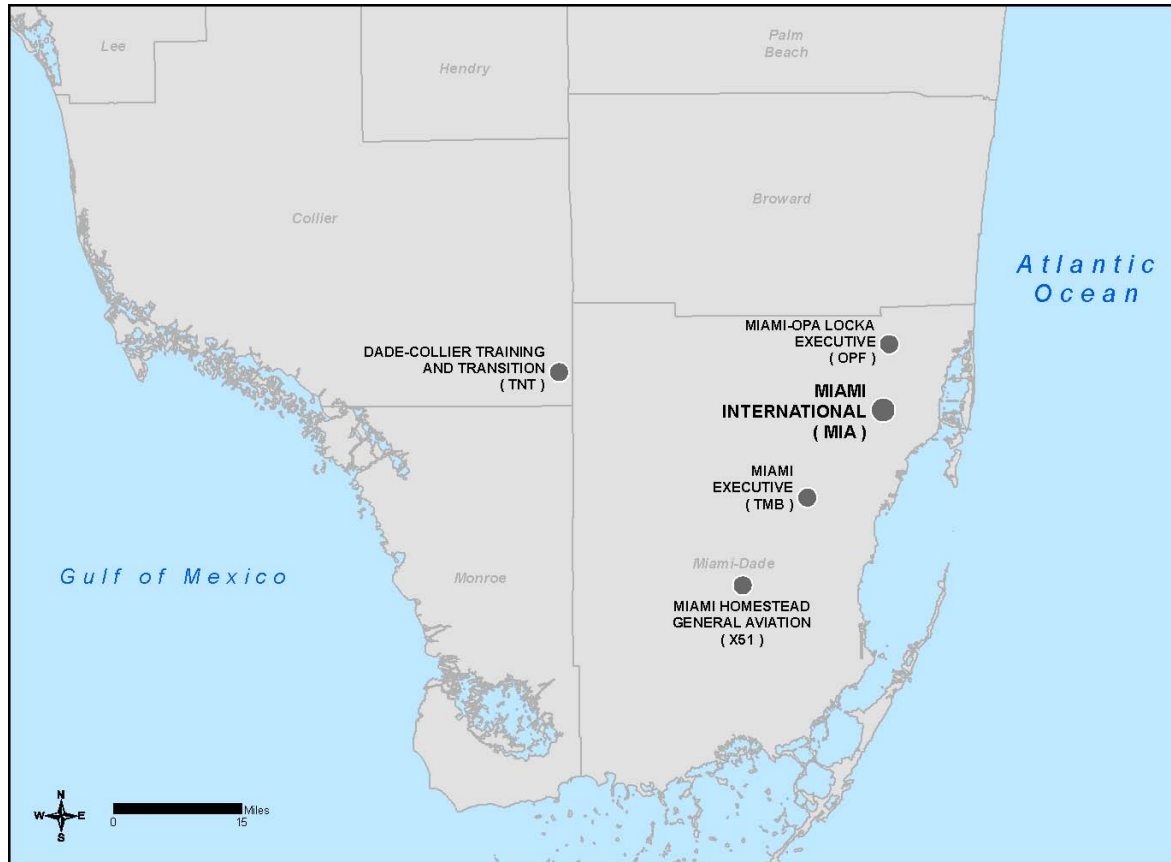

SOURCE: Airport Master Planning Study General Aviation Activity Forecasts, June 2012.
 PREPARED BY: Ricondo & Associates, Inc., August 2015.

The current airfield at TNT has one paved runway (9-27) configured to accommodate ADG V aircraft (wingspans less than 214 feet). Runway 9 is the only runway with published instrument approach procedures; **Table A-1** summarizes the predominant characteristics of the runway at TNT.

This ALP Narrative Report describes the planning and rationale that resulted in identification of a preferred development plan for TNT, and summarizes the set of drawings that make up the ALP set. The purpose of the ALP set is to provide airport management with a scaled, graphic presentation of the Airport's 20-year development program represented in the SMP by the 2015 – 2035 planning horizon. The set also provides information such as specific airport data (i.e.; runway coordinates, design aircraft), a graphical depiction of airspace surfaces (i.e.; Code of Federal Regulations (CFR) Part 77 imaginary surfaces, threshold siting surfaces), land use information, and property boundaries. These plans identify areas for future aviation related development. The ultimate configuration of airport facilities demonstrates a feasible improvement plan that provides for safe, compatible, and efficient airport operations.

Table A-1: Dade-Collier Training and Transition Airport - Runway Characteristics

CHARACTERISTIC	9-27
Length	10,499 feet
Width	150 feet
Runway Design Code	D-V
Approach Capability	Non-Precision
Lowest Visibility Minimums	1-mile

SOURCE: FAA Form 5010, Dade-Collier Training and Transition Airport, August, 2014; FAA Advisory Circular 150/5300-13A (Change 1), Airport Design, February 26, 2014; FAA Terminal Instrument Approach Procedures, December 2014.

PREPARED BY: Ricondo & Associates, Inc., August 2015.

The dimensional information provided in the drawings demonstrates compliance with minimum airport design standards established by federal, state, and local authorities. This ALP set has been developed in accordance with the guidance outlined in the FAA Advisory Circulars 150/5070-6B, Change 1, Airport Master Plans, and 150/5300-13A (Change 1) Airport Design and Florida Department of Transportation (FDOT) Guidebook for Airport Master Planning. Furthermore, it has been reviewed to comply with the ALP Checklist-ARP SOP 2.00 which can be found in Appendix A. The ALP set will be revised over time to reflect new facility and infrastructure development and proposed changes to planned development at TNT so that the FAA and Florida Department of Transportation (FDOT) will be continually updated to reflect current conditions.

The aeronautical forecasts for TNT include annual and peak period GA aircraft operations, as well as the number of based GA aircraft accommodated at the Airport in the 2010 Base Year and at two additional planning periods, referred to as planning activity levels (PALs):

- PAL 1 – reflective of the demand level projected for 2025 under the SMP’s Baseline Forecast
- PAL 2 – reflective of the demand level projected for 2035 under the SMP’s Baseline Forecast

The aeronautical forecasts represent unconstrained conditions for future GA activity without consideration of existing or potential capacity constraints. These forecasts also provide justification for planning and development recommendations contained in the SMP. The various forecast metrics, such as annual GA aircraft operations, annual itinerant operations by all aircraft, annual itinerant operation by the current and future critical aircraft, and the forecast of based aircraft at TNT, are summarized in **Table A-2**. Although the airfield was originally designed to serve B747-400 aircraft, the current critical aircraft for TNT is unknown, while the identification of a future critical aircraft would be speculative at this time.

MDAD intends to maintain the current airfield configuration and capabilities to serve as a testing and training facility for instrument approaches, keeping these aircraft operations out of the direct MIA airspace. MDAD also intends to use TNT if there is a need to divert an ADG V in the event of an emergency.

Table A-2: SMP Aviation Forecast Summary -Dade-Collier Training and Transition Airport

FORECAST METRIC	2010 (ACTUAL)	PAL 1 (2025)	PAL 2 (2035)
Annual General Aviation Aircraft Operations	14,468	16,100	17,300
Annual Itinerant Operation by all Aircraft	14,468	16,100	17,300
Annual Itinerant Operation by Current Critical Aircraft	Unavailable	Unavailable	Unavailable
Annual Itinerant Operation by Future Critical Aircraft	Unavailable	Unavailable	Unavailable
Based Aircraft	0	0	0
Annual Instrument Approaches	N/A	N/A	N/A
Annual Enplanements	N/A	N/A	N/A

SOURCES: URS Corporation, SMP General Aviation Forecasts, March 2012; Ricondo & Associates, Inc. August 2014.

PREPARED BY: Ricondo & Associates, Inc., August 2015.

A demand-capacity assessment of both the airfield and support facilities that serve aeronautical purposes was performed for TNT. Tenant facilities to support aeronautical users were not considered, as no tenant facilities currently exist at TNT, and none are anticipated throughout the planning horizon. Support facility requirements include consideration for aircraft parking and storage, automobile parking, aircraft fueling facilities, and airport support functions were also assessed. The airfield demand-capacity assessment concluded that TNT will have adequate capacity to accommodate demand forecast beyond PAL 2 (2035). No additional support facility requirements are expected over the next 20 years. However, at the request of MDAD, a secondary taxilane is proposed between the apron and the existing full length parallel taxiway. On that basis, there is only one development scenario developed for TNT that reflects the proposed construction of the additional taxilane.

As the only development proposed at TNT is a single taxilane connector to the aircraft parking ramp, a graphical representation of development sequencing was not warranted. It is anticipated that this airfield improvement would be implemented in the Phase 1 timeframe to facilitate MDAD's plan to conduct an unmanned aerial system exposition/air show at TNT in the near future. **Table A-3** presents the total implementation costs and proposed funding sources for the proposed taxilane at TNT.

Table A-3: Dade-Collier Training and Transition Airport - Preliminary Capital Funding Plan

	FAA AIRPORT IMPROVEMENT PROGRAM FUNDS	FDOT GRANTS	MIAMI DADE COUNTY FUNDS	THIRD PARTY INVESTOR	TOTAL
Runway/Taxiway Extension	\$2,856,000	\$159,000	\$159,000	\$0	\$3,174,000

NOTES:

- 1/ Project funding sources are estimates established in accordance with current funding eligibility guidelines and do not reflect a commitment by the FAA or FDOT to provide funds at this time.
- 2/ Costs are reflective of 2014 US dollars and include consideration for both hard (construction) and soft costs (design, permitting, and construction administration).

SOURCES: URS Corporation, Construction Costs, April 2014; Ricondo & Associates, Inc., SMP Technical Analyses, August, 2014.

PREPARED BY: Ricondo & Associates, Inc., August 2015.

In order to clearly present the existing conditions and recommended airport improvements, the ALP set includes a number of individual drawing sheets. The ALP sheet is essential in the process to apply for federal or state assistance for any individual development project and also serves as the mechanism for projects to undergo airspace review by the FAA. For TNT, the ALP set is presented on the following drawing sheets:

- Cover (1 of 7)
- Data Table (2 of 7)
- Existing and Future ALP (3 of 7)
- Airport Airspace Plan (4 of 7)
- Existing & Future Runway 9-27 Inner Portion of the Approach Surface Drawing (5 of 7)
- Airport Land Use Drawing (6 of 7)
- Airport Property Map (7 of 7) - Pending

Reduced reproductions of these drawings are included in **Appendix B** of this report for illustration purposes. A full-size set of the drawings is also being submitted with this report to the FAA and FDOT for review and acceptance.

B. Basic Aeronautical Forecasts

The aeronautical forecasts provide estimates for future aviation demand at the Airport. Projections of aviation demand are important in the planning process as they provide the basis for the orderly development of the Airport including:

- Documentation of the role of the Airport and determination of the type of aircraft to be accommodated in the ten and twenty-year planning period
- Evaluation of the capacity of existing airport facilities and their ability to accommodate proposed expansion.
- Estimation of extent of airside and landside facilities required to accommodate forecast traffic beyond the ten-year forecast.

A detailed *SMP General Aviation Activity Forecasts* (Aeronautical Forecast) report was developed for MDAD in June 2012 as part of the SMP and subsequently approved by the FAA in August 2012. The FAA approval letter is included as **Appendix C** of this document. The findings from that report are summarized below.

The aeronautical forecasts for TNT include annual and peak period GA aircraft operations, as well as the number of based GA aircraft accommodated at the Airport in the 2010 Base Year and at two planning activity levels:

- PAL 1 (2025)
- PAL 2 (2035)

The aeronautical forecasts represent unconstrained conditions for future GA activity without consideration of existing or potential capacity constraints. The forecasts also provide justification for planning and development recommendations contained in the SMP. These forecasts have been reviewed and approved by the FAA as being consistent with the most current FAA *Terminal Area Forecast* (TAF)¹, and provide justification for planning and development recommendations contained in the SMP.

The approach to forecasting future general aviation activity for MDAD's general aviation airports, including TNT, differs from the approach used to forecast air carrier activity at MIA. This is due to unique operational characteristics and role of each airport. Due to the diversity of the level of service and facilities offered at TNT,

¹ The most current FAA TAF available at the time the OPF Aeronautical Forecasts were prepared is dated January 2012.

as well as the recognition of limited availability of historical aircraft operations and based aircraft data, data reported in the FAA's Air Traffic Activity Data System (ATADS) and the Terminal Area Forecast (TAF) were used to forecast annual aircraft operations and based aircraft for all four general aviation airports. This approach reflects a "top-down" market share approach to forecasting in which current activity at an airport is calculated as a static share (percentage or ratio) of some other more aggregate external measure for which forecasts have already been produced. Then, an assumption is made about the Airport's future share of that activity.

Using general aviation-specific data, as contained in Table 28, "Active General Aviation and Air Taxi Aircraft," published in the FAA's *Aerospace Forecasts, FY 2012-2032*², forecasts of future year-over-year growth trends of the various types of active general aviation aircraft were developed. These trends served as the basis for the forecasts of general aviation activity by aircraft type for TNT, as well as the forecasts of based aircraft.

B.1 Total Annual Operations

As presented on **Exhibit B-1**, total annual general aviation aircraft operations at TNT is forecasted to increase from 14,468 in 2010 to 16,100 by 2025 and to 17,300 operations by 2035 at an average annual compound growth rate of 0.72 percent. The forecast year-over-year growth rate in the FAA TAF remains constant at 14,468 from 2010 through 2035.

B.2 Annual Itinerant Operations by all Aircraft

There are currently no local operations at TNT. It is also anticipated that this would continue to be the case in throughout the planning horizon, unless MDAD decides to change the role of the Airport. The annual itinerant operations by all aircraft at TNT will thus be the same as total annual general aviation aircraft operations that are shown in Exhibit B-1.

B.3 Annual Itinerant Operations by Current Critical Aircraft

In accordance with MDAD's landing weight reports for 2014, the critical aircraft for TNT is a combination of 14 aircraft types within or exceeding the Airport Reference Code of B-III. As shown in **Table B-1**, these aircraft types combined to represent 500 operations at TNT.

² The FAA's fiscal year (FY) is from October 1 through September 30.

B.4 Annual Itinerant Operations by Future Critical Aircraft

Due to the limited utility of TNT, annual itinerant operations by the critical aircraft types are not expected to change in the future.

Exhibit B-1: Dade-Collier Training and Transition Airport - Forecasts of General Aviation Aircraft Operations

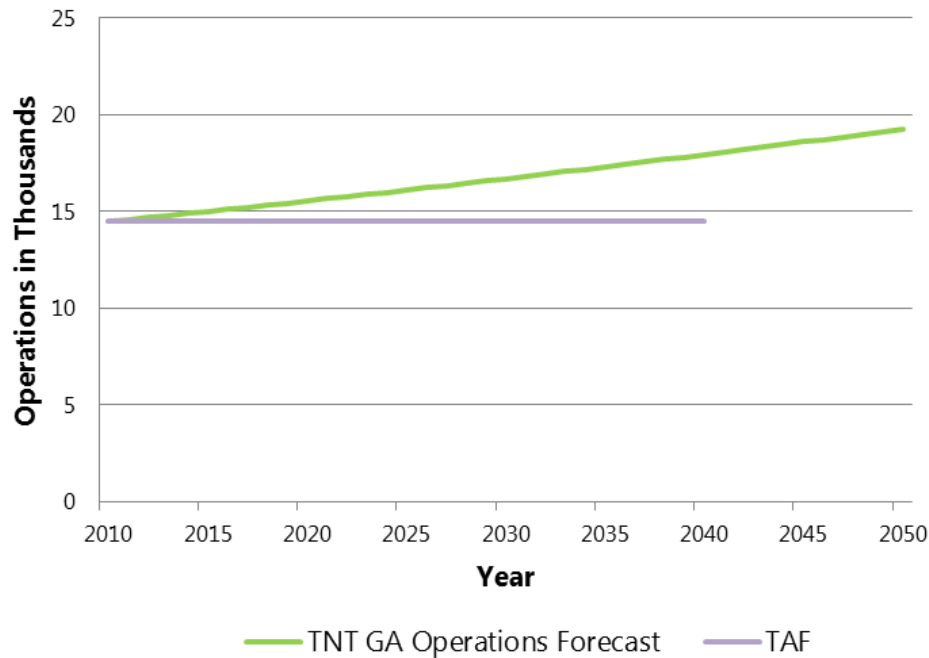

FISCAL YEAR	SMP GENERAL AVIATION OPERATIONS FORECAST FOR TNT	FAA TERMINAL AREA FORECAST
2010 (ACTUAL)	14,468	14,468
PAL 1 (2025)	16,100	14,468
PAL 2 (2035)	17,300	14,468
AACGR (2010 – 2035)	0.72%	0.00%

NOTES:

Fiscal year = October 1 through September 30

AACGR = Average Annual Compound Growth Rate

SOURCES: URS Corporation, SMP General Aviation Forecasts, March 2012; FAA Terminal Area Forecast, January 2012.

PREPARED BY: Ricondo & Associates, Inc., August 2015.

Table B-1: Dade-Collier Training and Transition Airport - 2014 Critical Aircraft Operations

AIRCRAFT TYPE	AIRCRAFT APPROACH CATEGORY	AIRPLANE DESIGN GROUP	ANNUAL OPERATIONS (2014)
CASA CN 235	C	III	228
Convair 440	C	III	82
Convair 340	C	III	68
Convair 131	C	III	30
Convair 580	C	III	20
Convair 29	C	III	14
Dash-8	B	III	14
B737/P8	C	III	14
DC-6	B	III	12
DC-3	B	III	10
MD88	C	III	2
A-320	C	III	2
Global Express	C	III	2
Gulfstream V	C	III	2
Total Annual Operations			500

SOURCES: 2014 TNT Aircraft Landing Report, Miami-Dade Aviation Department.

PREPARED BY: Ricondo & Associates, Inc., August 2015.

B.5 Number of Based Aircraft

The facility is currently available for use by general aviation users having prior permission and MDAD-issued permit, but is closed from sunset to sunrise. There are currently no dedicated fixed base operator (FBO) or other aeronautical-use facilities that serve the general aviation at TNT. As a result, there are no based aircraft at TNT. The limited use and role of TNT and its ability to attract and/or accommodate or generate additional aviation activity is not anticipated to change in the foreseeable future.

B.6 Annual Instrument Approaches

TNT is a non-towered airport that is primarily used to provide a precision-instrument landing and training facility in South Florida for commercial pilots, private training, and a small number of military touch-and-go's. While Runway 9-27 is served with precision approach path indicator (PAPIs), approach lighting system (ALS), LPV, RNAV and a non-directional (radio) beacon (NDB) that provide precision, non-precision, and circling

approaches, the actual number of annual instrument operations is uncertain. Furthermore, the level of instrument operations is not anticipated to increase to a level that would justify the need for additional instrument approach capability or trigger other capacity enhancement needs at the Airport.

B.7 Number of Enplanements

TNT is a general aviation and training airport with no scheduled or charter, air carrier, or cargo service. Furthermore, the Airport is not expected to introduce air carrier service during the planning horizon. Therefore, the forecasting of passenger or cargo enplanements is not warranted or applicable.

B.8 Critical Aircraft

The current critical aircraft at TNT is unknown and a projection of the future critical aircraft is speculative.

B.9 Runway Design Code

The Runway Design Code (RDC) is a coding system outlined in FAA Advisory Circular (AC) 150/5300-13A, Change 1, *Airport Design* as the basis for specifying applicable runway design standards. The intent of the RDC is to provide a method for compiling the numerous dimensional and performance specifications of aircraft operating at or forecast to operate at the Airport, into criteria that will define the dimensional and design standards for a given runway. The RDC consists of three parameters; Aircraft Approach Category (AAC), Airplane Design Group (ADG), and the approach visibility minimums.

TNT is composed of one runway: Runway 9-27. The following describes the RDC for Runway 9-27

- Airplane Approach Category – As originally configured for the B747-400, this aircraft falls within the Approach D category.
- Airplane Design Group – As originally configured for the B747-400, this aircraft falls within the ADG V category.
- Visibility Minimums - The Runway 9 end is equipped with an LPV, RNAV, and NDB approach, providing a visibility minimum of a 1 statute mile (5000 RVR). The Runway 27 end is not equipped with any instrument approach procedure and therefore has visual approach visibility minimums.

Combined, these three parameters result in an RDC of D/V/5,000 for Runway 9 and D/V/VIS for Runway 27. The RDC's for TNT are also summarized in **Table B-2**. The Airport's existing Airport Reference Code (ARC) is designated as D-V and no reconfiguration or resizing of any airfield element is warranted. While the level of ADG V aircraft operations at TNT is uncertain, maintaining the Runway to D-V standards through the planning period is preserved on the ALP.

Table B-2: Dade-Collier Training and Transition Airport – Runway Design Code

RUNWAYS	AIRPLANE APPROACH CATEGORY		AIRPLANE DESIGN GROUP		VISIBILITY MINIMUMS	
	EXISTING	FUTURE	EXISTING	FUTURE	EXISTING	FUTURE
Runway 9	D	Same	V	Same	5,000	Same
Runway 27	D	Same	V	Same	VIS	Same

SOURCES: Airport Layout Plan, Dade-Collier Training and Transition Airport, August 2014.

PREPARED BY: Ricondo & Associates, Inc., August 2015.

B.10 Runway Reference Codes

The Runway Reference Code (RRC) or the Approach and Departure Reference Codes (APRC and DPRC) describe the current operational capabilities of a runway and adjacent taxiways where no special operating procedures are necessary. The APRC consist of the same three parameters as the RDC (AAC, ADG, and Visibility Minimums) whereas the DPRC consists of the AAC and ADG only. The APRC and DPRC coding system is outlined in FAA AC 150/5300-13a (Change 1), *Airport Design*. The APRC and DPRC differ from the RDC as the RDC is based on planned development and has no operational application. The APRC and DPRC may change over time as improvements are made to the runway, taxiway, and NAVAIDs.

The APRC is determined based on the existing runway to taxiway separation and visibility minimums. At TNT, 700' separates the runway centerlines from their associated full length parallel taxiway centerline. The runway to taxiway separation combined with 1-mile visibility on Runway 9 and visual visibility on Runway 27 result in a D/VI/5,000 Runway 9 APRC and D/VI/VIS Runway 27 APRC.

The DPRC is determined based on the existing runway to taxiway separation. With 700-foot separation between the runway centerline and the taxiway centerline, the DPRC for Runway 9 and Runway 27 is D/VI. **Table B-3** summarizes the Approach and Departure Reference Codes for TNT.

Table B-3: Dade-Collier Training and Transition Airport – Approach and Departure Reference Codes

RUNWAYS	APRC		DPRC	
	EXISTING	FUTURE	EXISTING	FUTURE
Runway 9	D/VI/5,000	Same	D/VI	Same
Runway 27	D/VI/VIS	Same	D/VI	Same

SOURCES: Airport Layout Plan, Dade-Collier Training and Transition Airport, August 2014.

PREPARED BY: Ricondo & Associates, Inc., August 2015.

C. Alternatives/Proposed Development

C.1 Proposed Development Items

A demand-capacity assessment of both the airfield and support facilities that serve aeronautical purposes was performed for TNT. Tenant facilities to support aeronautical users were not considered, as tenant facilities currently do not exist at TNT, and none are anticipated throughout the planning horizon. The purpose of these assessments was to compare the capacity of existing facilities and infrastructure with current and future operational demand to determine when additional capital improvements would be required. When deficiencies were identified, future facility requirements were projected and quantified. A demand-capacity assessment was performed for the following facilities:

- Airfield
- Support Facilities
 - Automobile parking facilities
 - Aircraft fuel storage facilities
 - Airport administration offices and maintenance
 - Aircraft rescue and fire-fighting (ARFF) facilities

C.1.1 AIRFIELD

Exhibit C-1 graphically represents the airfield demand-capacity assessments for TNT. More specifically, the exhibit demonstrates the estimated operational demand at which the annual service volume (ASV) is projected to be reached. ASV represents the airfield's annual capacity given seasonal and daily fluctuations in demand.

From the airfield demand-capacity assessments, it was concluded that TNT would have adequate capacity to accommodate demand forecast beyond PAL 2 (2035). Although the forecast does not demonstrate a need for any airfield capacity improvements, MDAD has elected to perform some taxiway circulation improvements to improve efficiency of aircraft movements around the airfield by constructing a secondary taxilane between the apron and the parallel taxiway, which is the only planned development at TNT that is depicted on the ALP.

Exhibit C-1: Dade-Collier Training and Transition Airport - Airfield Demand-Capacity Comparison

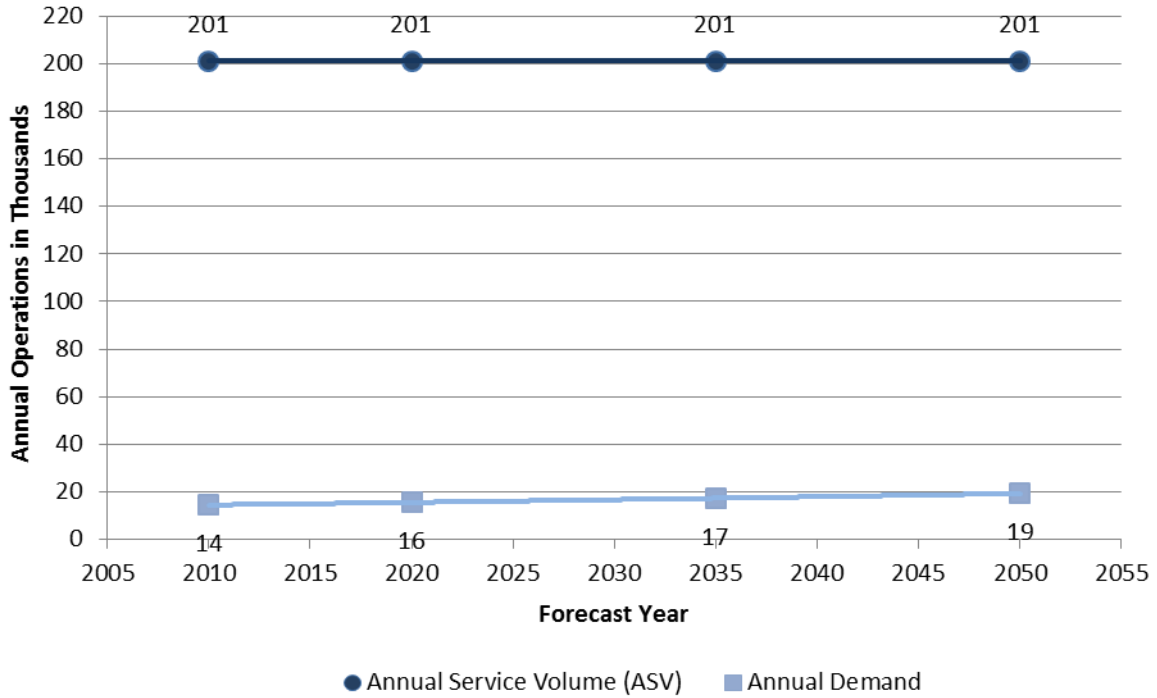

SOURCES: FAA Advisory Circular 150/5060-5A (Change 1), *Airport Capacity and Delay*, September 23, 1983; Ricondo & Associates, Inc., July 2012.
 PREPARED BY: Ricondo & Associates, Inc., August 2015.

C.1.2 SUPPORT FACILITIES

Table C-1 summarizes the facility requirements for TNT to satisfy the demand associated with PAL 2 (2035). These facility requirements include consideration for aircraft parking apron, automobile parking, aircraft fueling facilities, and airport support functions. While no additional facility requirements are expected over the next 20 years based on the PAL 2 forecast demand, a secondary apron taxiway connector is proposed between the apron and the existing full length parallel taxiway. All existing navigational aids, equipment, and runways are expected to serve both the Airport’s current and future needs.

Table C-1: Dade-Collier Training and Transition Airport – Tenant/Support Facility Needs

FACILITY TYPE	EXISTING	PAL 2 (2035) GROSS FACILITY REQUIREMENTS	ADDITIONAL FACILITIES TO SERVE PAL 2 (2035)
Aircraft Parking/Storage			
T-Hangars	0	0	0
Conventional Hangars	0	0	0
Apron/Ramp	264,300	264,300	0
Automobile Parking	1,600	1,600	0
Aviation Fuel			
100 LL	0	0	0
Jet A	0	0	0
Airport Support			
MDAD Maintenance Yard	25,000	25,000	0
MDAD Administration	1,500	1,500	0
MDAD Covered Parking	0	0	0
Aircraft Rescue and Fire-fighting Facilities	N/A	N/A	N/A
Total Facilities	292,200	292,200	0
		Aircraft Circulation Adjustment	0
		Drainage and Landscape Adjustment	0
		Total Adjusted PAL Requirements	0
		Acreage	0 acres

NOTES:

N/A = Not Applicable

Unless noted otherwise, all values are expressed in square feet.

SOURCE: Ricondo & Associates, Inc., and Jacobsen Daniels Associates, LLC SMP Technical Analyses, March 2013.

PREPARED BY: Ricondo & Associates, Inc., August 2015.

C.2 Near-Term and Future Approach Procedures Requirements

There are currently no near-term or future requirements that have been identified for the approach procedures at TNT.

C.3 Navigational Aids

TNT has both Visual and Instrument Approach Aids. **Table C-2** summarizes the various approach aids at TNT.

Table C-2: Dade-Collier Training and Transition Airport – Navigational Aids

RUNWAYS	RUNWAY LIGHTS		RUNWAY MARKING		VISUAL APPROACH AIDS		INSTRUMENT APPROACH AIDS	
	EXISTING	FUTURE	EXISTING	FUTURE	EXISTING	FUTURE	EXISTING	FUTURE
Runway 9	HIRL	Same	Precision	Same	MALSR	Same	GPS, DME, NDB	Same
Runway 27	HIRL	Same	Precision	Same	PAPI (P4L)	Same	None	Same

SOURCE: Airport Layout Plan, Dade-Collier Training and Transition Airport, August 2014.

PREPARED BY: Ricondo & Associates, Inc., August 2015.

C.4 Wind Coverage

Runway 9-27 provides 99.9% all weather wind coverage assuming a 16 knot crosswind component. The wind coverage exceeds the FAA requirement for consideration of a crosswind runway. There are no additional runways proposed for TNT.

D. Modification to Standards

There are currently no modifications to standards for TNT. It is anticipated that with the future development to accommodate the demands through PAL 2, there would still be no need for any modifications to standards.

E. Obstruction Surfaces

There are currently no threshold siting surface penetrations and no obstructions to 14 CFR Part 77 that have been identified.

F. Runway Protection Zone

There are currently no incompatible land uses within the existing RPZs, nor are any anticipated in the future.

G. Development Summary

Although no future tenant or support facility development is projected for TNT, a single development scenario was generated for the Airport, which reflects the future construction of the taxiway connector between the aircraft parking apron and the parallel taxiway. **Exhibit G-1** illustrates the recommended development scenario for the TNT.

Order-of-Magnitude Cost Estimates

For the development scenario, an engineer's estimate of probable costs was prepared for the recommended development scenario for TNT. These costs include consideration of construction costs, and soft costs associated with design, permitting, bidding, construction and program management. **Table G-1** summarizes the estimated costs for implementation at TNT, expressed in 2013 dollars.

Table G-1: Dade-Collier Training and Transition Airport - Engineer's Estimate of Probable Costs

COST ITEM	TNT
Enabling Projects	\$0
Construction (hard costs)	\$1,876,000
Construction (soft costs)	\$710,000
Total	\$2,586,000

NOTES:

All values are expressed in 2013 dollars.

SOURCE: URS Corporation, Construction Costs, April 2014.

PREPARED BY: Ricondo & Associates, Inc., August 2015.

G.1 Development Projects Completed Since Last ALP

No new development projects have been undertaken and completed at TNT since the last approved ALP.

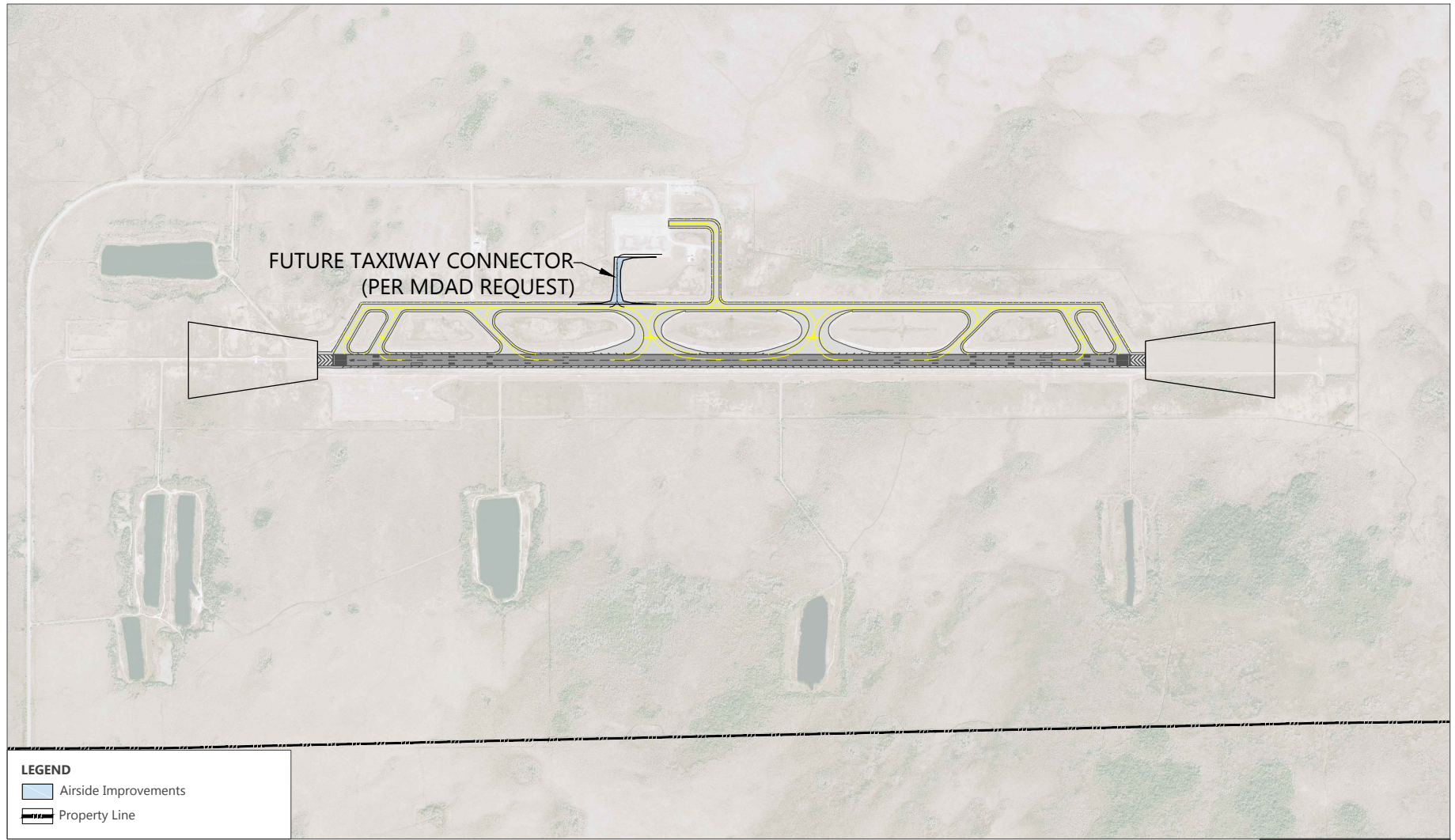

SOURCE: Woolpert TNT Aerial Photography, flown February 2014; Ricondo & Associates, Inc., and Jacobsen-Daniels Associates, LLC, Land Use Development Alternatives April 2014.
PREPARED BY: Jacobsen/Daniels Associates, May 2014.

EXHIBIT G-1

Dade-Collier Training and Transition Airport Development Scenario

G.2 Implementation Plan

For capital improvement planning considerations, the facility and infrastructure development initiatives associated with the preferred development scenario was categorized into one of four development phases. Each phase reflects a 5-year period, as follows:

- Phase 1 (2016 - 2020)
- Phase 2 (2021 – 2025)
- Phase 3 (2026 – 2030)
- Phase 4 (2031 – 2035)

As the only development proposed at TNT is a single taxiway connector to the aircraft parking ramp, a graphical representation of development sequencing was not warranted. It is anticipated that this airfield improvement would be implemented in the Phase 1 timeframe.

H. Shadow or Line-of-Sight Study

There is currently no operational tower as a result of this there are no shadow or line-of-sight studies underway for TNT.

I. Letters of Coordination

This section is Not Applicable to this ALP Narrative. The Only coordination that was done was with Miami-Dade Aviation Department and Miami-Dade County.

J. Wildlife Hazard Management

A wildlife hazard assessment has not been performed for TNT and the county presently does not have a formal Wildlife Hazard Mitigation Plan. The Airport has no based jets and therefore falls into Airport Group 4 of the FAA's Wildlife Hazard Assessment Implementation Schedule. In accordance with the FAA's implementation schedule, MDAD intends on completing a wildlife hazard assessment prior to 2020.

K. Preliminary Identification of Environmental Features

Exhibits K-1 through **K-7** illustrate the various environmental features at OPF and within the surrounding environs. **Table K-1** summarizes the potential environmental impacts associated with the proposed development depicted on the Future ALP and the proposed mitigation approach for those areas that may be directly impacted. As shown, these impacts are limited to encroachment of two existing canals within the Airport property boundary, which would be converted into a box culvert to allow for the realignment of Taxiway R and the expansion of the remote aircraft parking hardstands to the east of the North Terminal Complex.

TNT is surrounded by the Big Cypress National Preserve, which is intended to protect the surrounding marsh and swamps that feed into Everglades National Park. It is also adjacent to Water Conservation Area 3A to the east. The Big Cypress National Preserve is also established as a sanctuary for the Florida Panther, which is on the endangered species list both under the Ecological Society of America and in the state of Florida. There are no documented observations of the Florida Panther within the confines of the airside operating area at TNT.

The availability of other information pertaining to the environmental features at TNT is limited. Since the scope of the SMP did not include an inventory of environmental constraints, an extensive inventory of environmental features of the Airport cannot be documented. Given the limited scope of the proposed improvements at TNT, significant environmental impacts are not anticipated.

Table K-1: Summary of Potential Environmental Impacts

ENVIRONMENTAL FEATURE	DESCRIPTION OF POTENTIAL IMPACTS	MITIGATION APPROACH
Major Drainage Ditches	Taxiway R Relocation Aircraft Hardstand Expansion	Convert Canal to Box Culvert Convert Canal to Box Culvert
Wetlands	No Direct Impacts	N/A
Flood Zones	Cargo Expansion (Zone AH)	Grading and Drainage as Required
Historical or Cultural Resources	No Direct Impacts	N/A
DOT Section 4(f) Features	No Direct Impacts	N/A
Flora/Fauna	No Direct Impacts	N/A
Natural Resources	No Direct Impacts	N/A
Other Features	None Identified	N/A

Notes:

N/A = Not Applicable

Flood Zone AH corresponds to the areas of the 100-year shallow flooding with a constant water-surface elevation where average depths are between 1 and 3 feet. Mandatory flood insurance purchase requirements apply.

Sources: Miami-Dade Aviation Department; ESRI Database: Esri, DigitalGlobe, GeoEYE, i-cubed, United States Department of Agriculture, AEX, Getmapping, Aerogrid, IGN, swisstopo, and the GIS User Community (Aerial Photography), 2015; Florida Geographic Data Library, GIS Metadata Explorer; GIS Data, <http://www.fgdl.org/metadataexplorer/explorer.jsp> (accessed September 29, 2015); United States Geological Survey, GIS Data: Hydrography, <http://nhd.usgs.gov/data.html> (accessed September 25, 2015; Miami-Dade County GIS Data;

Prepared by: Ricondo & Associates, Inc., September 2015

[Preliminary Draft for Discussion Purposes Only]

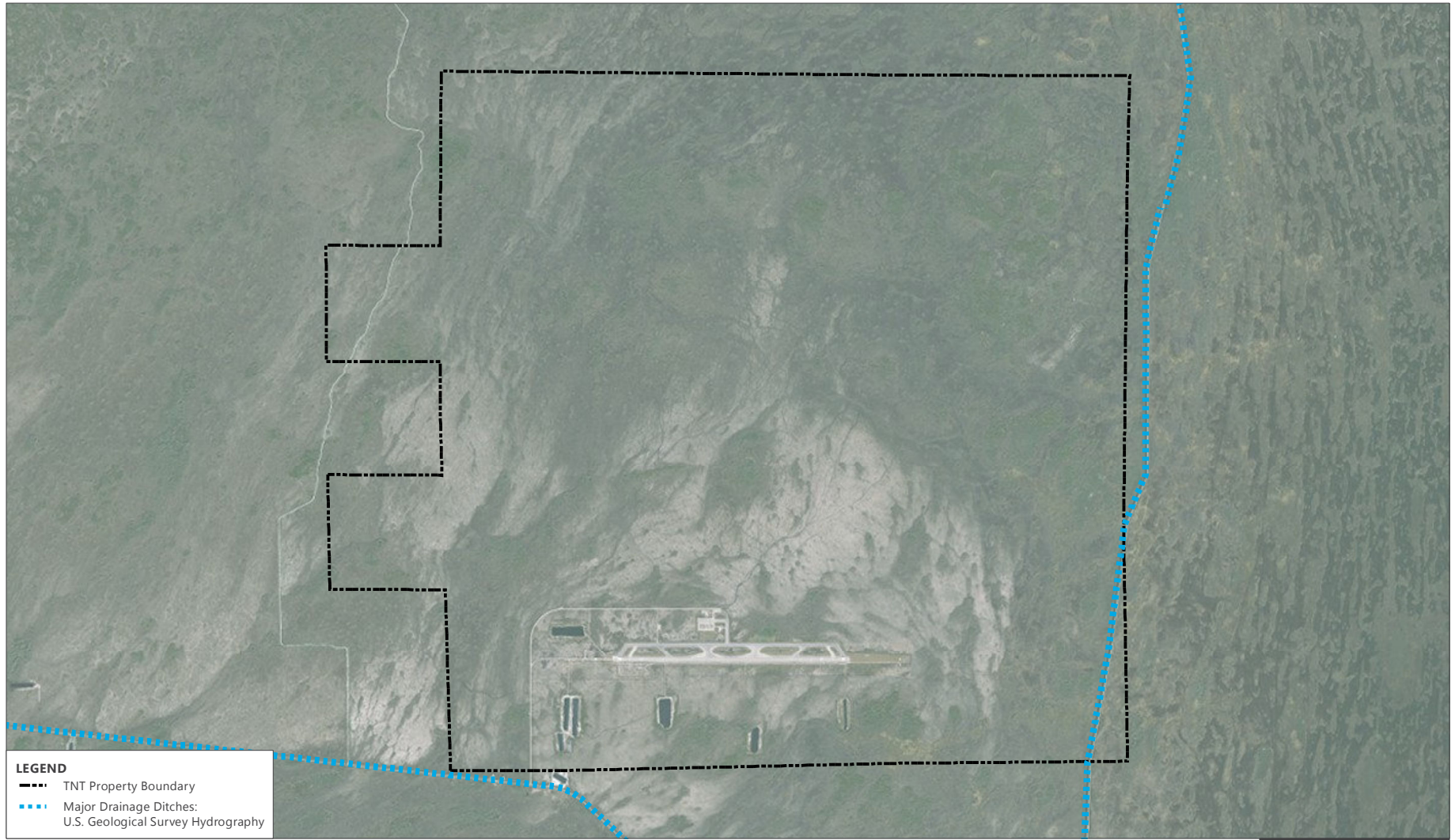

SOURCES: Miami-Dade County Aviation Department; Esri, DigitalGlobe, GeoEye, Earthstar Geographics, CNES/Airbus DS, USDA, USGS, AeroGRID, IGN, and the GIS User Community, December 2017 (aerial basemap); U.S. Geological Survey, GIS Data: Hydrography, <http://nhd.usgs.gov/data.html>, (accessed: September 25, 2015).
PREPARED BY: Ricondo & Associates, Inc., September 2015.

EXHIBIT K-1



Major Drainage Ditches

W:\Projects\MIA\Environmental Analysis\MXD\TNT_Environmental_Analysis_01_Drainage_2017-12-01.mxd

[Preliminary Draft for Discussion Purposes Only]

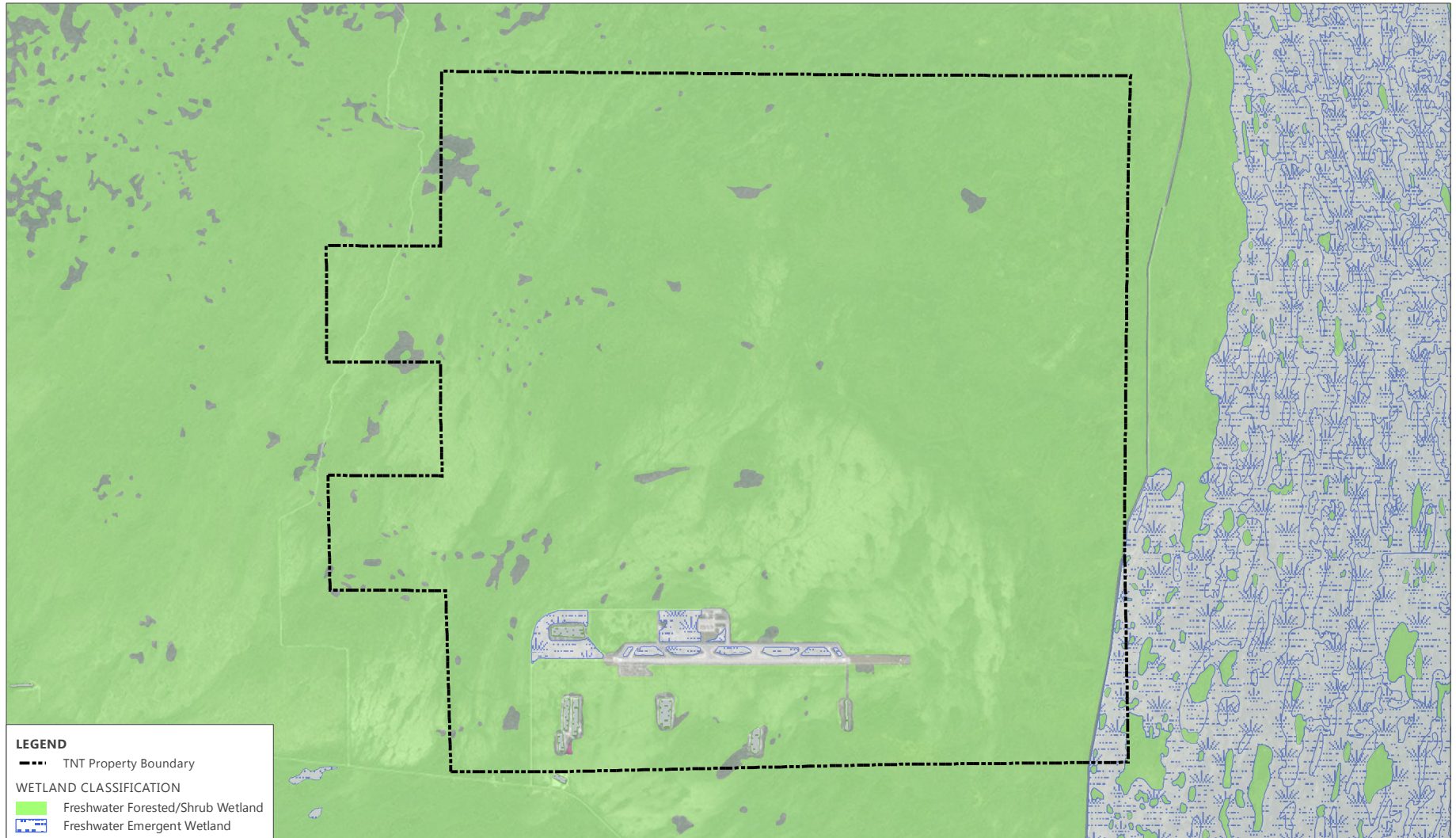

LEGEND

- TNT Property Boundary

WETLAND CLASSIFICATION

- Light Green Freshwater Forested/Shrub Wetland
- Blue with Grid Freshwater Emergent Wetland

SOURCES: Miami-Dade County Aviation Department; Esri, DigitalGlobe, GeoEye, Earthstar Geographics, CNES/Airbus DS, USDA, USGS, AeroGRID, IGN, and the GIS User Community, December 2017 (aerial basemap); Florida Geographic Data Library, GIS Metadata Explorer: GIS Data, <http://www.fgdl.org/metadataexplorer/explorer.jsp>, (accessed, September 29, 2015); PREPARED BY: Ricondo & Associates, Inc., September 2015.

EXHIBIT K-2

 NORTH

 0 7,000 ft.

W:\Projects\MIA\Environmental Analysis\MXD\TNT_Environmental_Analysis_02_Wetlands_2017-12-01.mxd

Wetlands

[Preliminary Draft for Discussion Purposes Only]

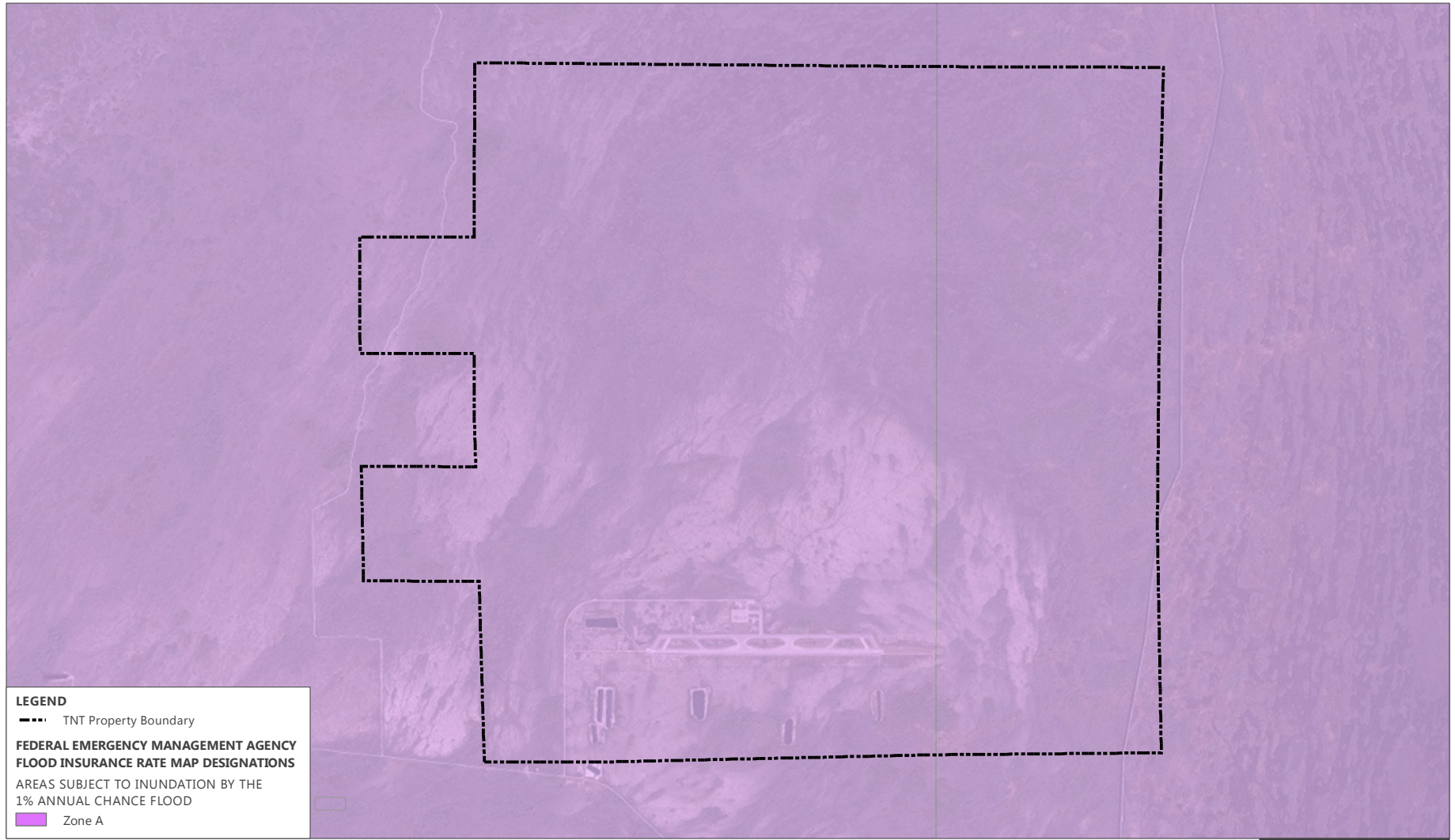

SOURCE: Miami-Dade County Aviation Department; Esri, DigitalGlobe, GeoEye, Earthstar Geographics, CNES/Airbus DS, USDA, USGS, AeroGRID, IGN, and the GIS User Community, December 2017 (aerial basemap); Florida Geographic Data Library, GIS Metadata Explorer: GIS Data, <http://www.fgdl.org/metadataexplorer/explorer.jsp>, (accessed, September 29, 2015); PREPARED BY: Ricondo & Associates, Inc., September 2015.

EXHIBIT K-3



Flood Zones

W:\Projects\MIA\Environmental Analysis\MXD\TNT_Environmental_Analysis_03_Floodzones_2017-12-01.mxd

[Preliminary Draft for Discussion Purposes Only]



LEGEND
- - - TNT Property Boundary
CULTURAL RESOURCE CLASSIFICATION
● State Historic Preservation Office (SHPO) Cultural Resources

SOURCE: Miami-Dade County Aviation Department; Esri, DigitalGlobe, GeoEye, Earthstar Geographics, CNES/Airbus DS, USDA, USGS, AeroGRID, IGN, and the GIS User Community, December 2017 (aerial basemap); Florida Geographic Data Library, GIS Metadata Explorer: GIS Data, <http://www.fgdl.org/metadataexplorer/explorer.jsp>, (accessed, September 29, 2015); PREPARED BY: Ricondo & Associates, Inc., September 2015.

EXHIBIT K-4

NORTH

0 7,000 ft.

W:\Projects\MIA\Environmental Analysis\MXD\TNT_Environmental_Analysis_04_Cultural_2017-12-04.mxd

Cultural Resources

[Preliminary Draft for Discussion Purposes Only]



SOURCE: Miami-Dade County Aviation Department; Esri, DigitalGlobe, GeoEye, Earthstar Geographics, CNES/Airbus DS, USDA, USGS, AeroGRID, IGN, and the GIS User Community, December 2017 (aerial basemap); Miami-Dade County, GIS Data; PREPARED BY: Ricondo & Associates, Inc., September 2015.

EXHIBIT K-5



Department of Transportation (DOT) Section 4(f) Features

W:\Projects\MIA\Environmental Analysis\MXD\TNT_Environmental_Analysis_05_DOT_4f_2017-12-04.mxd

[Preliminary Draft for Discussion Purposes Only]

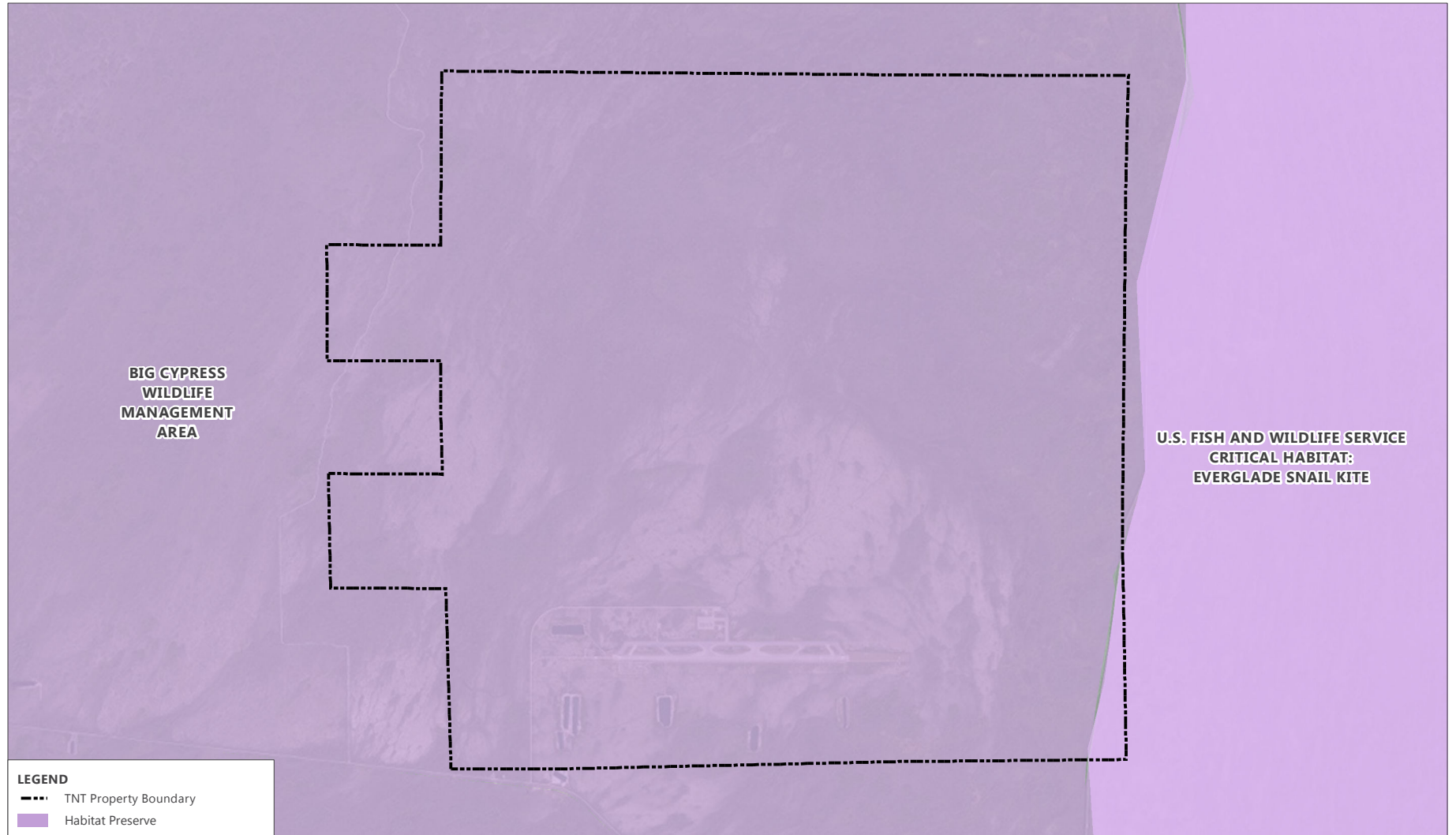

SOURCE: Miami-Dade County Aviation Department; Esri, DigitalGlobe, GeoEye, Earthstar Geographics, CNES/Airbus DS, USDA, USGS, AeroGRID, IGN, and the GIS User Community, December 2017 (aerial basemap); Florida Geographic Data Library, GIS Metadata Explorer: GIS Data, <http://www.fgdl.org/metadataexplorer/explorer.jsp>, (accessed, September 29, 2015); U.S. Fish and Wildlife Service, GIS Data: Critical Habitat, <http://ecos.fws.gov/crithab/>, (accessed: September 29, 2015).
 PREPARED BY: Ricondo & Associates, Inc., September 2015.

EXHIBIT K-6

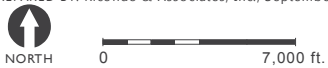

Flora and Fauna

W:\Projects\MIA\Environmental Analysis\MXD\TNT_Environmental_Analysis_06_flora_fauna_2017-12-04.mxd

[Preliminary Draft for Discussion Purposes Only]

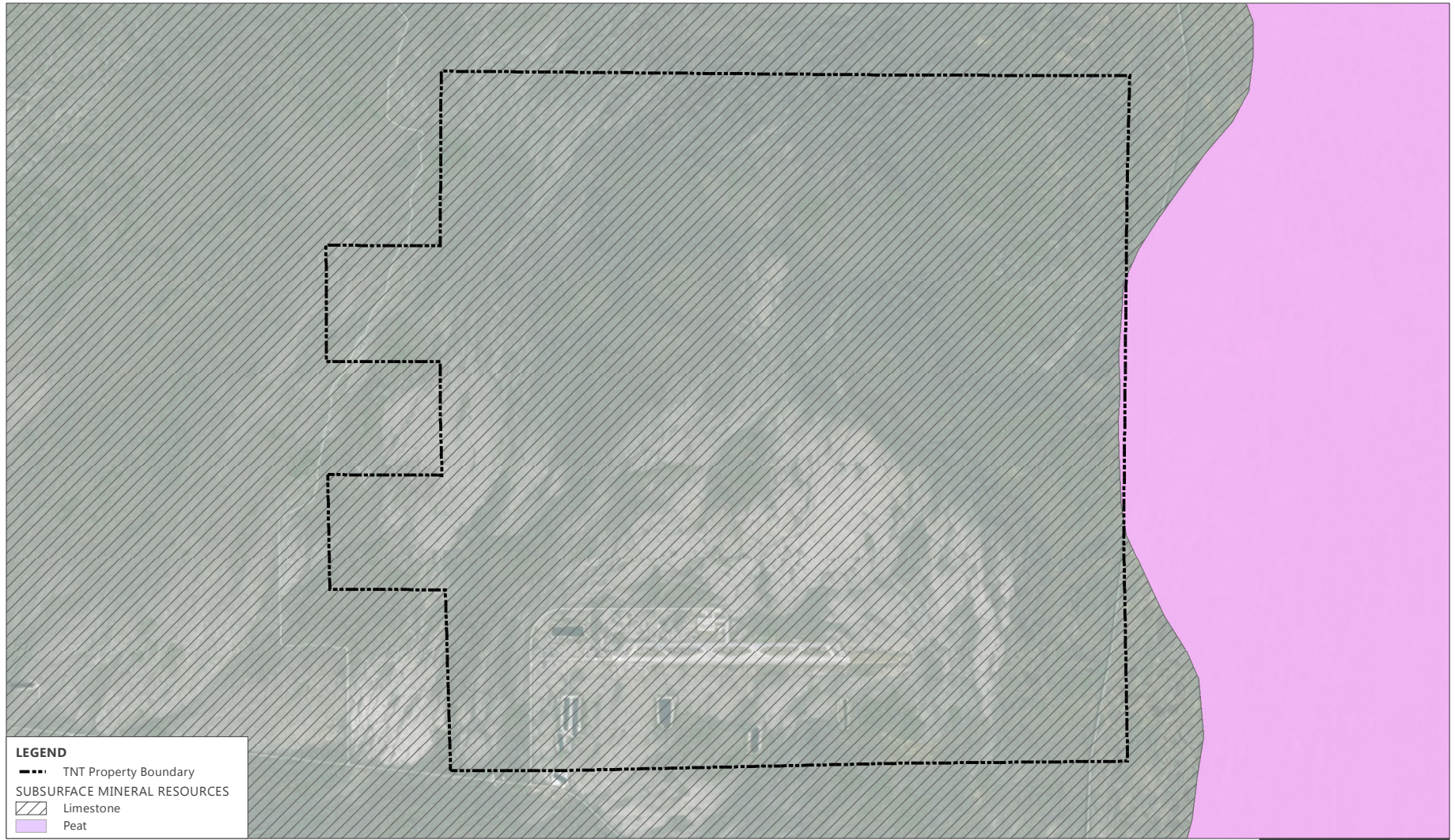

LEGEND
- - - TNT Property Boundary
SUBSURFACE MINERAL RESOURCES
Limestone
Peat

SOURCE: Miami-Dade County Aviation Department; Esri, DigitalGlobe, GeoEye, Earthstar Geographics, CNES/Airbus DS, USDA, USGS, AeroGRID, IGN, and the GIS User Community, December 2017 (aerial basemap); Florida Geographic Data Library, GIS Metadata Explorer: GIS Data, <http://www.fgdl.org/metadataexplorer/explorer.jsp>, (accessed, September 29, 2015); PREPARED BY: Ricondo & Associates, Inc., September 2015.

EXHIBIT K-7



Natural Resources

W:\Projects\MIA\Environmental Analysis\MXD\TNT_Environmental_Analysis_07_Na_Resources_2017-12-04.mxd

L. Action Items from Runway Safety Program Office

This section is Not Applicable as there are currently no action items from the Runway Safety Program office. All safety areas are in compliance with FAA standards.

M. Declared Distances

The declared distances table is used to aid in identifying the maximum distances available and suitable for meeting takeoff, rejected takeoff, and landing distances performance requirements for turbine powered aircraft. TNT does not have displaced thresholds, stopways, or clearway, and has standard Runway Safety Areas (RSA), Runway Object Free Areas (ROFA), Runway Projection Zones (RPZ), and Threshold Siting Surface (TSS) as a result of this the Takeoff Run Available (TORA), Takeoff Distance Available (TODA), Accelerate-Stop Distance Available (ASDA), and Landing Distance Available (LDA) will be equal to the runway length. **Table M-1** identifies the TORA, TODA, ASDA, and LDA for the three runways.

Table M-1: Dade-Collier Training and Transition Airport – Declared Distance

	TORA		TODA		ASDA		LDA	
	EXISTING	FUTURE	EXISTING	FUTURE	EXISTING	FUTURE	EXISTING	FUTURE
Runway 9	10,499	Same	10,499	Same	10,499	Same	10,499	Same
Runway 27	10,499	Same	10,499	Same	10,499	Same	10,499	Same

NOTES:

Unless noted otherwise, all values are expressed in square feet.

SOURCES: Airport Layout Plan Dade-Collier Training and Transition Airport, August 2015.

PREPARED BY: Ricondo & Associates, Inc., August 2015.

N. Airport Layout Plan Drawings

The following sections provide a brief description of the information specific to each of the drawing sheets that comprise the ALP set. These drawings were developed and produced as a set on 36 inches by 24 inches sheets using AutoCAD MAP 3D 2013 software. To provide vertical and horizontal accuracy for the ALP set, a digitized map was flown in April 2008 and was used as a base for all the drawings. The aerial image was flown in 2014 and provided by MDAD. The coordinates, elevations, and aerial photogrammetry are in U.S. Survey Feet. The horizontal datum is Florida State Plane Coordinate System, East Zone, North American Datum of 1983/1990 adjustment (NAD 83/90). The vertical datum is the North American Vertical Datum of 1988 (NAVD 88).

Reduced reproductions of these drawings are included in this report in Appendix B for illustration purposes. A full-size set of the drawings will be submitted to the FAA and FDOT for review and acceptance. An ALP set will provide airport management with an overall guidance on the direction for future development possibilities on the Airport property.

N.1 Cover Sheet

Sheet one, the Cover/Title Sheet, lists the subsequent drawings within the ALP set. It also provides the reader a location and vicinity map. The location map is a scaled representation of location of the Airport in the State of Florida, and a vicinity map shows the approximate location of the Airport, its boundary, and major roadways. The vicinity map also depicts the roadway system serving the Airport and the local community.

N.2 Data Sheet

Sheet 2, the Data Sheet, contains six data tables used in the ALP set.

- **Airport Data Table** - This table lists existing and future information specific to the Airport, such as Airport elevation, service level, role, reference code, design aircraft, owner, Airport Reference Point, temperature information, and available navigational aids.
- **Runway Data Table** - This table is a compiled tabulation of information relating specifically to runways at the Airport. Various specifications are listed for each existing and future runway, including, but not limited to: runway location, dimensions, design group, available lighting and navigational aids, as well as safety areas as defined in AC 150/5300-13A.

- **Wind Rose and Wind Coverage Table** - The sheet also includes the Airport's wind roses. The wind data depicted on this sheet was obtained from the National Oceanic and Atmosphere Administration's (NOAA) National Climatic Data Center and is reflective of observations at Miami International Airport, as not weather data is collected at TNT. The wind data information is provided for all weather conditions, visual metrological conditions (ceiling at or above 1,000 feet and visibility greater than or equal to 3 miles), and instrument metrological conditions (ceiling below 1,000 feet and /or visibility less than 3 miles). These components detail the percentage of time a runway end or combination of ends or runways are available for arrivals. When combined, the coverage is intended to be as near as possible to 100 percent. The Wind Rose depicts the runway orientation and percentages over which winds from a given direction occur. The box width varies based on the crosswind component desired and is intended to graphically portray the information displayed in the Wind Coverage Table. The wind coverage is summarized for the runway ends. The historic wind data was obtained for TNT for the ten-year period beginning on January 2005 and ending on January 2014.
- **Drawing Index Table** – this table identifies the subsequent drawings within the ALP set.

N.3 Existing and Future Airport Layout Plan

The Existing & Future ALP sheet is provided as a reference document to graphically depict both existing facilities and future developments that will be necessary to meet the forecast demand over the next 20-30 year period. It represents the Airport in its entirety at a scale of 1 inch = 600 feet. The Existing and Future ALP sheet is a graphic presentation of the actual layout of the existing and proposed facilities at TNT. Major features of the ALP drawing include runways, taxiways, aprons, navigational aids, existing facilities, the roadway system, and non-airport facilities surrounding the perimeter of the Airport's property boundary. This drawing also includes information from the cover sheet for runway approaches, runway end elevations, runway high and low points, true azimuths for each runway, and the angle of declination (magnetic north) including the annual rate of change for the magnetic declination. It also includes pertinent clearance and dimensional information associated with the runways and taxiways such as runway safety areas, runway protection zones. Imaginary elements are included on the drawing sheet including airport reference point (existing/future), ground contours, and other dimensional data recommended by the FAA.

The sheet also graphically depicts the proposed development that is consistent with the project recommended under Section C.1.2. Proposed development includes the additional apron taxiway connector is proposed between the apron and the existing full length parallel taxiway.

N.4 Airport Airspace Plan

To enhance the safe operation of aircraft in the airspace around the Airport, the FAA has adopted FAR Part 77 "Safe, Efficient Use, and Preservation of the Navigable Airspace." Subpart C of FAR Part 77 establishes imaginary surfaces for determining obstructions to air navigation. FAR Part 77 surfaces are utilized in zoning and land use

planning adjacent to the Airport to protect the navigable airspace from encroachment by hazards, which could potentially affect the safety of airport operations.

The Airport Airspace Drawing (Sheet 3) depicting the 14 CFR Part 77 imaginary airspace surfaces for the Airport. The Airport Airspace Drawing illustrates the physical features on and around the Airport, including any existing obstructions that penetrate the FAR Part 77 imaginary surfaces. These imaginary surfaces are intended to provide airports and sponsors with a mechanism to evaluate existing and proposed objects as part of the 7460 process for determining hazards to air navigation. FAR Part 77 surfaces correspond to available navigational aids and types of approaches available to a runway end. The specific imaginary surfaces depicted on these drawing include:

- **Primary Surfaces** – Longitudinally centered on each runway, this surface extends 200 feet beyond each end of the runway and has an elevation equal to that of the runway centerline. The width of the primary surface is that prescribed for the most precise instrument approach procedure, existing or planned, for either end of the runway. The primary surface for TNT’s runway is 500 feet wide because Runway 9 offers a non-precision approach.
- **Approach Surfaces** - These surfaces are longitudinally centered along the extended centerline and extend outward and upward from each end of the primary surface. The size and slope of the approach surface is based upon the type of approach, existing or planned, for that runway end. The inner edge of the approach surface is the same width as the primary surface. However, its overall length, slope, and outermost width may vary. **Table N-1** summarizes the characteristics of the existing and future approach surfaces at the Airport.
- **Transitional Surfaces** - These surfaces extend outward and upward from the lateral edges of all primary and approach surfaces with a slope of 7 to 1.
- **Horizontal Surface** – This surface is a plane located 150 feet above the established airport elevation. Its perimeter is composed of arcs of specific radii connected by lines tangent to the arcs. The arcs are centered on the midpoint of the ends of all the primary surfaces.
- **Conical Surface** – This surface extends outward and upward from the periphery of the horizontal surface at a slope of 20:1, for a horizontal distance of 4,000 feet.

Table N-1: Dade-Collier Training and Transition Airport - CFR Part 77 Approach Surface Characteristics

RUNWAY END	OVERALL LENGTH (IN FEET)	OUTERMOST WIDTH (IN FEET)	SLOPE
Runway 9	10,000	3,500	34:1 ^{1/2}
Runway 27	5,000	1,500	20:1

NOTES:

Unless noted otherwise, all values are expressed in square feet.

1/ Precision instrument approach slope is 50:1 for inner 10,000 feet and 40:1 for an additional 40,000 feet.

SOURCE: Safe, efficient use, and preservation of navigable airspace, 14 CFR Part 77, September 2008.

PREPARED BY: Ricondo & Associates, Inc., August 2015.

NAVAIDS that have frangible mounts are fixed-by-function and were not included in the obstruction analysis at TNT, per FAR Part 77. Aside from NAVAIDS, there were no obstructions penetrating the Part 77 Surfaces. Obstacle and obstruction data was used from the 2007 ALP. The obstruction data was obtained from the National Aeronautical Charting Office (NACO) in August 2005.

N.5 Existing & Future Inner Portion of the Approach Surface Drawings

The Inner Approach Surface Drawings (Sheet 4) are prepared for each of the runway approaches and consists of scaled drawings of the area immediately beyond the existing runway ends at TNT, including but not limited to the RPZs off each runway end. It is recommended by the FAA that the area within each RPZ should be kept free of obstacles that could constitute a hazard to aircraft approaching or departing the Airport. These drawings depict the location of roadways, structures, natural ground elevations, and other man-made or natural features within the limits of each RPZ or out to where the ultimate approach surface slope is 100 feet above the threshold elevation, whichever is further. The drawings also detail objects that penetrate existing and proposed approach surfaces or violate the primary surface criteria. No penetrating obstructions were identified on any of the inner portions of the approach surfaces at TNT.

All obstacle and obstruction data was used from the 2007 ALP. The obstruction data was obtained from NACO in August 2005, and all obstacle data was obtained from NOAA and National Geodetic Survey (NGS) in February 2005.

N.6 Airport Land Use Drawing

Land use planning allows coordinating use of the Airport property in a manner compatible with the functional design of the airport facility. Airport land use planning is important for the orderly development and efficient use of available space. There are two primary considerations for airport land use planning: first, to secure those areas essential for the safe and efficient operation of the Airport; and second, to determine compatible land uses for the balance of the property that would be most advantageous to the Airport and community.

The Airport Land Use Drawing illustrates the proposed utilization of property within the existing boundary of the Airport. This drawing identifies various land use designations for airport owned property ranging from Airport Operations Areas covering portions of the Airport utilized by aircraft or those areas required to meet FAA design and safety requirements, to Big Cypress National Preserve and other natural resources. The land use areas, and their location on and around the airfield, are described below and are depicted using various patterns of hatching on the sheet.

- Future Aviation Related Use – This land use is intended for aviation-related development, such as general aviation aircraft hangars, cargo and/or maintenance repair overhaul facilities, and airfield access improvements including taxiways and taxilanes. This land use also includes future aircraft parking areas. This land identifies those portions of the Airport that are undeveloped or underdeveloped with the potential for the development of one or more forms of aviation.
- Airport Operation Area (AOA) – This consists of the land area reserved for activities supporting and sustaining the safe and efficient operation of aircraft including land devoted to airfield facilities such as runways and taxiways and property within the limits of the RPZ, Runway Object Free Area, and Taxiway Object Free Area.
- Natural Resource / Vacant & Everglades National Park – This consists of the land area managed and operated by the Florida Game and Freshwater Fish Commission.

N.7 Airport Property Map

The Airport Property Map presents a historical chronology of all land conveyances associated with the Airport that are available from public records. It illustrates the property boundary and identifies the various parcels that were acquired in the 1960s to create this boundary. This sheet identifies the parcel information such as the grantor, record data, acreage, date, etc. The Airport Property Map serves as a method of tracking current Airport property and as a place in which to depict and identify future property acquisition or easements that may be necessary for future Airport development. The Airport Property map drawing is pending receipt of available information from MDAD.

Appendix A ALP Checklist – ARP SOP 2.0



ALP REVIEW CHECKLIST

The following checklist shall be used in lieu of FAA AC 150/5070-6B, Appendix F, Airport Layout Plan Drawing set. This checklist is intended for use when submitting a new or updated ALP to the FAA for review and approval. Consultants and/or sponsors should indicate “Yes,” “No” or “N/A” (not applicable) for every item on the checklist. The same checklist shall be provided to FAA for review and verification. For all reviewers: It is important that each item listed be shown on the respective plan.

Airport Identification (to be completed by Sponsor or Consultant)

Airport	Dade-Collier Training and Transition Airport		
City and State	Miami, FL	Location Identifier	TNT
Airport Owner	Miami-Dade County		

ALP Submission Information (to be completed by Sponsor or Consultant)

ALP Prepared by	Jacobsen-Daniels Associates	
	Name of Consulting Firm	
	Chris Johnson / Robert Tykoski	12/2017
	Name of Individual	Date
	(734) 961-3200	
	Telephone	
	robertt@jacobsendaniels.com	
	Email address	
Consulting QA/QC Review	David Ramacorti, C.M. (Director)	12/2017
	Name and Title of Individual	Date
Sponsor Review	Ammad Riaz P.E. (Chief Aviation Planning Division)	
	Name and Title of Individual	Date

FAA Review (to be completed by FAA)

	Name and Title of Individual	Date

Effective Date: October 1, 2013

ARP SOP No. 2.00

Critical Design Aircraft or Family of Aircraft:

	Make	Model	Annual Itinerant Operations
Existing	De Havilland	Dash-8	500 (Cumulative of all B-III Aircraft Operations)
Future	Same	Same	Same

Forecasted Year: 2035

Airport Reference Code (ARC): D-V

Runway Design Code (RDC) & Runway Reference (RRC):

Runway	RDC	RRC
9	D/V/5000	D/V/5000
27	D/V/VIS	D/V/VIS

Approach Minimums:

Rwy End	Minimum	Rwy End	Minimum
9	200 – 1-Mile	27	Visual

Runways (Existing and Future):

Runway	Existing		Future		Departure Surface (Y or N/A)
	Length (ft)	Width (ft)	Length (ft)	Width (ft)	
9/27	10,499	150	10,499	150	N/A

For the balance of the checklist, enter a mark ( or X) to confirm inclusion.

Item	Instructions	Sponsor/Consultant			FAA
		Yes	No	N/A	
A. Executive Summary – A concise summary of the findings/ recommendations of the master planning effort or changes to the ALP. This should include a description of planned projects, an implementation plan/timeline, and identification of benchmarks or actions that will be conducted to either verify the original planning assumptions or proceed with project implementation.	<p>From AC 150/5070-6, Section 202: An accompanying ALP Narrative Report should explain and document those changes and contain at least the following elements:</p> <ul style="list-style-type: none"> - Basic aeronautical forecasts. - Basis for the proposed items of development. - Rationale for unusual design features and/or modifications to FAA Airport Design Standards. - Summary of the various stages of airport development and layout sketches of the major items of development in each stage. - An environmental overview to document environmental conditions that should be considered in the identification and analysis of airport development alternatives and proposed projects. 				
1. Identify Projects along with description		X			
2. Create a Timeline for each Project		X			
3. Identify and List:					
a. Proposed Projects (e.g., Hangar development)		X			
b. Milestones/ Triggering Events (e.g., 1. All hangars are full, 2. There is a waiting list long enough to fill a new development, 3. Hangars have reached their useful life, etc.)		X			
c. Action items/Next Steps (e.g., 1. Maintain log and gather data, 2. Discuss plan with ADO, 3. Coordinate with ADO regarding potential for inclusion in FAA ACIP (Airports Capital Improvement Program), 4. Identify funding sources.)				X	
d. Funding Plan		Capital Improvement Plan for the forecast horizons. See AC 150/5070-6, Chapter 11. Only a rough, order-of-magnitude report	X		

	is needed in the executive summary.				
B. Basic aeronautical forecasts (0-5, 6-10, 11-20 years): Basic aeronautical forecasts (0-5, 6-10, 11-20 years):	Forecasts of future levels of aviation activity as approved by the FAA. These projections are used to determine the need for new or expanded facilities. See AC 150/5070-6, Chapter 7.				
1. Total annual operations	Total local and itinerant aircraft operations at the airport.	X			
2. Annual itinerant operations by all aircraft	Itinerant operations by aircraft that leaves the local airspace, generally 25 miles or more from the airport. See AC 150/5070-6, Chapter 7, Section 702.a. and Figure 7-2.	X			
3. Annual itinerant operations by current critical aircraft		X			
4. Annual itinerant operations by future critical aircraft		X			
5. Number of based aircraft	Aircraft that use the subject airport as a home base, i.e., have hangar or tie-down space agreements. See AC 150/5070-6, Chapter 7, Section 702.a. and Figure 7-2.	X			
6. Annual instrument approaches	Number of instrument approaches expected to be executed during a 12-month period. See AC 150/5070-6, Chapter 7, Section 702.a. and Figure 7-2.			X	
7. Number of enplanements	See AC 150/5070-6, Chapter 7, Section 702.a. and Figure 7-2.			X	
8. Critical Aircraft (also referred as "design aircraft" or "critical design aircraft")	The critical aircraft is the most demanding aircraft identified in the forecast that will use the airport. Federally funded projects require that the critical aircraft will make substantial use of the airport in the planning period. Substantial use means either 500 or more annual itinerant operations or scheduled service. The critical aircraft may be a	X			

	single aircraft or a composite of the most demanding characteristics of several aircraft. Provide the aircraft, AAC, and ADG. (e.g. Boeing 737-400, C-III) See AC 150/5300-13A, Paragraph 105(b) and FAA Order 5090.3C, 3-4.				
9. Runway Design Code (RDC)	Describe the RDC for each runway. For the purpose of airport geometric design, each runway will contain a RDC which signifies the design standards to which the runway is to be built. The RDC consists of three parameters: Aircraft Approach Category (AAC), Airplane Design Group (ADG) and the approach visibility minimums. These parameters represent the aircraft that are intended to be accommodated by the airport, regardless of substantial use. See AC 150/5300-13A, Paragraph 105(c).	X			
10. Runway Reference Code (RRC)	Describe the RRC for each runway. The RRC describes the current operational capabilities of a runway where no special operating procedures are necessary. The RRC consists of the same three components as the RDC, but is based on planned development and has no operational application. See AC 150/5300-13A, Paragraph 318.	X			
C. Alternatives/Proposed Development					
11. Explanation of proposed development items	Specific projects can be described as project listings on a master table, on individual project data sheets, or in projects booklets.	X			
12. Discuss near-term and future Approach Procedure Requirements or effects (e.g., LPV, Circling, etc.)	Based on existing or forecast usage. See FAA Order 7400.2, Figures 6-6-3 and 6-3-9.	X			
13. Navigational Aids or Other Equipment Needs (e.g., Approach Lights, Wind	The need for new or additional navigational aids is a function of the fleet mix, the percentage of time that poor weather conditions	X			

Cones, AWOS, etc.)	are present, and the cost to the users of not being able to use the airport while it is not accessible.				
14. Wind coverage. Is it adequate for existing and future runway layouts? Has wind data been updated?	This analysis determines if additional runways are needed to provide the necessary wind coverage. Reference AC 150/5300-13A, Appendix 2 for guidance on wind coverage analysis techniques.	X			
D. Modification to Standards.	Any approved nonconformance to FAA standards, other than dimensional standards for RSAs and OFZs, require FAA approval. A description of all approved modification to standards shall be provided. See AC 150/5300-13A, Paragraph 106(b) and FAA Order 5300.1.	X			
E. Obstruction Surfaces (14 CFR Part 77 and Threshold Siting Surface)	Reference 14 CFR Part 77 and AC 150/5300-13A, Paragraph 303.	X			
F. Runway Protection Zone	A description of any incompatible land uses inside the RPZ shall be provided. Prior to including new or modified land use in the RPZ, the Regional and ADO staff must consult with the National Airport Planning and Environmental Division, APP-400. This policy is exempt from existing land uses in the RPZ. See AC 150/5300-13A, Paragraph 310 and FAA memorandum dated September 27, 2012.	X			
G. Development summary (including sketches, schedules, and cost estimates) for stages of construction for: Development summary (including sketches, schedules, and cost estimates) for stages of construction for:	Documentation provided should include any electronic spreadsheets and files to facilitate in modifying the financial plan on an as-needed basis.				
15. Development Projects Completed Since Last ALP		X			
16. 0-5 years		X			

17. 6-10 years				X	
18. 11-20 years				X	
H. Shadow or line-of-sight study for towered airports (negative or positive statements are required).	Reference FAA Order 6480.4. This can be from the Airway Facilities Tower Integration Laboratory (AFTIL) or simpler GIS-generated studies.			X	
I. Letters of coordination with all levels of government, as needed.	Affected private and/or governmental groups, agencies, commissions, etc., that may have input on the plans. See AC 150/5070-6, Chapter 3.			X	
J. Wildlife Hazard Management Issues Review (in narrative).	Reference AC 150/5200-33.	X			
K. Preliminary Identification of Environmental Features	Potential or known features only. Further environmental analysis will be necessary. Reference FAA Order 5050.4B. Begin framework for NEPA analysis.				
19. Major airport drainage ditches		X			
20. Wetlands				X	
21. Flood Zones				X	
22. Historic or Cultural features				X	
23. Section 4(f) features				X	
24. Flora/Fauna				X	
25. Natural Resources				X	
26. Etc. (other features identified in Order 5050.4B)				X	
L. Note Action Items from Runway Safety Program Office	List and note status of items from Runway Safety Program Office or Runway Safety Action Plan.			X	
M. Declared Distance (DD)	The narrative on declared distances is used to aid in understanding the maximum distances available and suitable for meeting takeoff, rejected takeoff, and landing distances performance requirements for	X			

Effective Date: October 1, 2013

ARP SOP No. 2.00

	<p>turbine powered aircraft. The narrative shall also provide clarification on why declared distances have been implemented. Declared distances data must be listed for all runway ends. The TORA, TODA, ASDA, and LDA will be equal to the runway length in cases where a runway does not have displaced thresholds, stopways, or clearway, and have standard RSAs, ROFAs, RPZs, and TSS. Reference AC 150/5300-13A, Paragraph 323.</p>				
Remarks					

A.1. Title Sheet

- The scale of the Title Sheet should be developed to include the items listed below.
- The minimum size for the final drawing set is 22” X 34” (ANSI D) and 24” X 36” (ARCH D). Coordinate use of 34” x 44” (ANSI E) and 26” X 48” (ARCH E) with FAA. Color drawings may be acceptable if they are still usable if reproduced in grey scale.

Item	Instructions	Sponsor/Consultant			FAA
		Yes	No	N/A	
A. Title and revision blocks	Each drawing in the Airport Layout Plan drawing set shall have a Title and Revision Block. For drawings that have been updated, e.g., as-builts, the revision block should show the current revision number and date of revision.	X			
B. Airport sponsor approval block	Provide an approval block for the sponsoring authority's representative to sign. Include space for name, title, and date.		X		
C. Date of ALP (date the airport sponsor signs the ALP)	The month and year of signature prominently shown near the title.	X			
D. Index of sheets (including revision date column)	Airport Layout Drawing, Airport Airspace Drawing, Inner Portion of the Approach Surface Drawing, Terminal Area Drawing, Land Use Drawing, Airport Property Map, Airport Departure Surface, etc.	X			
E. State Aeronautics Agency Approval Block (as needed)	Provide an approval block for the sponsoring authority's representative to sign. Include space for name, title, and date.			X	
F. State outline with county boundaries. County in which airport is located should be highlighted.	Provide as needed.	X			
G. Location map (general area)		X			
H. Vicinity map (specific airport area)		X			

Effective Date: October 1, 2013

ARP SOP No. 2.00

Remarks

A.2. Airport Data Sheet

- For smaller airports, some of the ALP sheets may be combined if practical and approved FAA.

Item	Instructions	Sponsor/Consultant			FAA
		Yes	No	N/A	
A. Title and Revision Blocks	Each drawing in the Airport Layout Plan drawing set shall have a Title and Revision Block. For drawings that have been updated, e.g., as-builts, the revision block should show the current revision number and date of revision.	X			
B. Wind Rose (all weather and IFR) with appropriate airport reference code and runway orientation depicted, crosswind coverage, and combined coverage, source of wind information and time period covered (for IFR runways applicable minimums should be included):	Assembly and analysis of wind data to determine ultimate runway orientation and also provides the operational impact of winds on existing runways. If instrument procedures are present or will be requested then both all-weather and instrument meteorological condition wind roses are required. See AC 150/5300-13A, Appendix 2.	X			
1. 10.5, 13, 16, 20 knots wind rose (based on appropriate airport reference code)	When a runway orientation provides less than 95 percent wind coverage for any aircraft forecasted to use the airport on a regular basis, a crosswind runway is recommended. The 95 percent wind coverage is computed on the basis of the crosswind not exceeding 10.5 knots for Airport Reference Codes A-I and B-I, 13 knots for Airport Reference Codes A-II and B-II, 16 knots for Airport Reference Codes A-III, B-III, and C-I through D-III, and 20 knots for Airport Reference Codes A-IV through D-VI. See also AC 150/5300-13A, Paragraph 302(c)(3) and AC 150/5300-13A, Appendix 2.	X			
2. Percentage of wind coverage/crosswind		X			
3. Source of data	Wind data may be obtained from NOAA at http://www.ncdc.noaa.gov/	X			

	Reference AC 150/5300-13A, Appendix 2, Paragraph A2-5 and A2-6.				
4. Age of data (last 10 consecutive years of data with most current data no older than 10 years)	Data must be from the latest 10-year period from the reporting station closest to the airport. Reference AC 150/5300-13A, Appendix 2, Paragraph A2-5.	X			
C. Airport Data Table					
1. ARC for Airport	List the Airport Reference Code (ARC) for airport. 5300-13AARC is an airport designation that signifies the airport's highest Runway Design Code (RDC), minus the third (visibility) component of the RDC. Reference AC 150/5300-13A.	X			
2. Mean maximum temperature of hottest month	List the mean maximum temperature and the hottest month for the airport location as listed in "Monthly Station Normals of Temperature, Precipitation, and Heating and Cooling Degree-Days" (Climatography of the United States No. 81). See AC 150/5325-4, 506.b.	X			
3. Airport elevation (highest point of the landing areas, nearest 0.1 foot) – using North American Vertical Datum of 1988 (NAVD88)	List the Airport Elevation, the highest point on an airport's usable runway expressed in feet above mean sea level (MSL). Use NAVD88. Reference AC 150/5300-13A, Paragraph 102(g) All elevations shall be in NAVD88. A note shall be put on the Airport Layout Drawing that denotes that the NAVD88 vertical control datum was used.	X			
4. Airport Navigational Aids, including ownership (NDB, TVOR, ASR, Beacon, etc.)	List the electronic aids available at the airport.	X			
5. Airport reference point coordinates, nearest second (existing, future if appropriate, and ultimate) - NAD83	List the Airport Reference Point, the latitude and longitude of the approximate center of the airport. Use the North American Datum of 1983 (NAD83) coordinate system. See AC 150/5300-13A, Paragraph 207. All latitude/longitude coordinates shall be in NAD83. A note shall	X			

	be put on the Airport Layout Drawing that denotes that the NAD83 coordinate system was used.				
6. Miscellaneous facilities (taxiway lighting, lighted wind cone(s), AWOS, etc.) [Including type/model and any facility critical areas]	List any other facilities available at the airport.	X			
7. Airport Reference Code and Critical Aircraft (existing & future)	List the existing and ultimate Airport Reference Code and Critical Aircraft, the most demanding aircraft identified in the forecast that will use the airport. Federally funded projects require that critical design airplanes have at least 500 or more annual itinerant operations at the airport (landings and takeoffs are considered as separate operations) for an individual airplane or a family grouping of airplanes. See AC 150/5325-4, 102.a.(8) and AC 150/5070-6, 702.a. Indicated dimensions for wingspan and undercarriage, along with approach speed.	X			
8. Airport magnetic variation, date and source	Magnetic declination may be calculated at http://www.ngdc.noaa.gov/geomagnetic-web/#declination . This model is using the latest World Magnetic Model which has an Epoch Year of 2010. See FAA Order 8260.19, "Flight Procedures and Airspace." Chapter 2, Section 5, for further information.	X			
9. NPIAS service level (GA, RL, P, CS, etc.)	See FAA Order 5090.3C.	X			
10. State equivalent service role	As applicable pursuant to State Aviation Department System Plan.	X			
D. Runway Data Table	The Runway Data Table should show information for both existing and ultimate runways.	X			
1. Runway identification (Include identifying	A column for each runway end should be present. List the runway end number and if	X			

runways that are "utility")	pavement strength is less than 12,500 pounds (single-wheel), then note as utility.				
2. Runway Design Code (RDC)	5300-13A The first component, depicted by a letter, is the AAC and relates to aircraft approach speed (operational characteristics). The second component, depicted by a Roman numeral, is the ADG and relates to either the aircraft wingspan or tail height (physical characteristics); whichever is more restrictive. The third component relates to the visibility minimums expressed by RVR values in feet of 1200, 1600, 2400, and 4000. List the RDC for each runway. See AC 150/5300-13A, Paragraph 105(c).	X			
3. Runway Reference Code (RRC)	The RRC describes the current operational capabilities of a runway where no special operating procedures are necessary. Like the RDC, it is composed of three components: AAC, ADG, and visibility minimums. List the RRC for each Runway. See AC 150/5300-13A, Paragraph 318.	X			
4. Pavement Strength & Material Type	Indicate the runway surface material type, e.g., turf, asphalt, concrete, water, etc.	X			
a. Strength by wheel loading	List the existing and ultimate design strength of the landing surface. See AC 150/5320-6, Chapter 3.	X			
b. Strength by PCN	See AC 150/5335-5.	X			
c. Surface treatment	Note any surface treatment: grooved, PFC, etc.	X			
5. Effective Runway Gradient (%) Author to note maximum grade within runway length. Note to included statement that the runway meets line of sight requirements	List the maximum longitudinal grade of each runway centerline. See AC 150/5300-13A, Paragraph 313.	X			
6. Percent (%) Wind	List the percent wind coverage for each runway for each Aircraft	X			

Coverage (each runway)	Approach Category. See AC 150/5300-13A, Appendix 2.				
7. Runway dimensions (length and width)	Dimensions determined for the Critical Design Aircraft by using graphical information in AC 150/5325-4.	X			
8. Displaced Threshold	Provide the pavement elevation of the runway pavement at any displaced threshold. See AC 150/5300-13A, Paragraph 303(2).	X			
9. Runway safety area dimensions (actual existing and design standard)	List the existing and ultimate dimensions of the Runway Safety Area (RSA). See AC 150/5300-13A, Paragraph 307.	X			
10. Runway end coordinates (NAD83) (include displaced threshold coordinates, if applicable) to the nearest 0.01 second and 0.1 foot of elevation.	Show the latitude and longitude of the threshold center and end of pavement (if different) to the nearest .01 of a second and 0.1 foot of elevation.	X			
11. Runway lighting type (LIRL, MIRL, HIRL)	List the existing and ultimate type of runway lighting system for each runway, e.g., Reflectors, Low Intensity Runway Lighting (LIRL), Medium Intensity Runway Lighting (MIRL), or High Intensity Runway Lighting (HIRL). LIRLs will typically not be shown for new systems. See AC 150/5340-30, Ch. 2.	X			
12. Runway Protection Zone (RPZ) Dimensions	List the existing and ultimate Runway Protection Zone (RPZ) dimensions. See AC 150/5300-13A, Paragraph 310. Prior to including new or modified land use in the RPZ, the Regional and ADO staff must consult with the National Airport Planning and Environmental Division, APP-400. This policy is exempt from existing land uses in the RPZ. See AC 150/5300-13A, Paragraph 310 and FAA memorandum dated September 27, 2012.	X			
13. Runway marking type (visual or basic, non-precision, precision)	Indicate the existing and ultimate pavement markings for each runway. See AC 150/5340-1,	X			

	Section 2.				
14. 14 CFR Part 77 approach category (50:1; 34:1; 20:1) Existing and Future	List the existing and ultimate approach surface slope. See FAA Order 7400.2, Figures 6-6-3 and 6-3-9.	X			
15. Approach Type (precision, non-precision, visual)	List the existing and ultimate Part 77 Approach Use Types. See FAA Order 7400.2, Figures 6-6-3 and 6-3-9.	X			
16. Visibility minimums (existing and future)	List the existing and ultimate visibility minimums for each runway. See AC 150/5300-13A, Table 1-3.	X			
17. Type of Aeronautical Survey Required for Approach (Vertically Guided, not Vert. Guided)	List the type of aeronautical survey required for the visibility minimums given. See AC 150/5300-18, Section 2.7 and AC 150/5300-13A, Table 3-4 and Table 3-5.	X			
18. Runway Departure Surface (Yes or N/A)"	Determine applicability of 40:1 Departure Obstacle Clearance Surface (OCS) as defined in Paragraph 303(c) of AC 150/5300-13A.	X			
19. Runway Object Free Area	List the existing and ultimate dimensions of the Runway Object Free Area (OFA). See AC 150/5300-13A, Paragraph 309. Objects non-essential for air navigation or aircraft ground maneuvering purposes must not be placed in the ROFA, unless a modification to standard has been approved.	X			
20. Obstacle Free Zone	The OFZ clearing standard precludes aircraft and other object penetrations, except for frangible NAVAIDs that need to be located in the OFZ because of their function. Modification to standards does not apply to the OFZ. List the Runway OFZ, Inner-approach OFZ, Inner-transitional OFZ, and Precision OFZ if applicable.	X			
21. Threshold siting surface (TSS)	List the existing and ultimate threshold siting surface (i.e. approach and departure	X			

	surfaces). Identify any objects penetrating the surface. If none, state "No TSS Penetrations". Reference AC 150/5300-13A, Paragraph 303.				
22. Visual and instrument NAVAIDs (Localizer, GS, PAPI, etc.)	List the existing and ultimate visual navigational aids serving each runway.	X			
23. Touchdown Zone Elevation	List the highest runway centerline elevation in the existing and ultimate first 3000 feet from landing threshold. See FAA Order 8260.3, Appendix 1.	X			
23. Taxiway and Taxilane width	List the existing and ultimate width of the taxiways and taxilane. Reference AC 150/5300-13A, Paragraph 403 and Table 4-2.	X			
24. Taxiway and Taxilane Safety Area dimensions	List the existing and ultimate taxiway and taxilane safety area dimensions. Reference AC 150/5300-13A, Paragraph 404(c) and Table 4-1.	X			
25. Taxiway and Taxilane Object Free Area	List the existing and ultimate taxiway and taxilane object free area dimensions. Reference AC 150/5300-13A, Paragraph 404(b) and Table 4-1.	X			
26. Taxiway and Taxilane Separation	List any objects located inside the Taxiway/Taxilane Safety Area and Taxiway/Taxilane Object Free Area. Also provide the distance from the taxiway/taxilane centerline to the fixed or movable object. Reference Paragraph 404(a) and Table 4-1.	X			
27. Taxiway/Taxilane lighting	List the existing and ultimate type of taxiway lighting system, e.g., Reflectors, Low Intensity Taxiway Lighting (LITL), Medium Intensity Taxiway Lighting (MITL), or High Intensity Taxiway Lighting (HITL). LITLs will typically not be shown for new systems. See AC 150/5340-30, Chapter 4.	X			
28. Identify the vertical and horizontal datum	All latitude/longitude coordinates shall be in North American Datum of 1983 (NAD 83). A note shall be put on the Airport Layout	X			

	<p>Drawing that denotes that the NAD 83 coordinate system was used.</p> <p>All elevations shall be NAVD88. A note shall be put on the Airport Layout Drawing that denotes that the NAVD88 vertical control datum was used.</p>				
E. Modification to Standards Approval Table (if applicable, a separate written request, including justification, should accompany the modification to standards). Show: Approval Date/ Airspace Case No. / Standard to be Modified / Description	<p>Provide a table to list all FAA approved Modifications to Standards. See AC 150/5300-13A, Paragraph 106(b), and FAA Order 5300.1.</p> <p>List "None Required" on the table if no Modifications have yet been proposed or approved.</p>	X			
F. Declared Distances Table	<p>Required even if Declared Distances are not in effect. Declared distances are only to be used for runways with turbine-powered aircraft. The TORA, TODA, ASDA, and LDA will be equal to the runway length in cases where a runway does not have displaced thresholds, stopways, or clearways, and have standard RSAs, ROFAs, RPZs, and TSS. Reference AC 150/5300-13A, Paragraph 323.</p>				
1. Take Off Run Available (TORA)	<p>List the runway length declared available and suitable for the ground run of an airplane taking off, i.e., Take Off Run Available (TORA). The TORA may be reduced such that it ends prior to the runway to resolve incompatible land uses in the departure RPZ, and/or to mitigate environmental effects. Reference AC 150/5300-13A, Paragraph 323(d)(1).</p>	X			
2. Take Off Distance Available (TODA)	<p>List the length of remaining runway or clearway (CWY) beyond the far end of the TORA ADDED TO the TORA. The resulting sum is the Take Off Distance Available (TODA) for the runway. The TODA may be reduced to mitigate penetrations to the 40:1 instrument departure surface, if applicable. The TODA</p>	X			

	may also extend beyond the runway end through the use of a clearway Reference AC 150/5300-13A, Paragraph 323(d)(2).				
3. Accelerate Stop Distance Available (ASDA)	5300-13A List the length the length of runway plus stopway (if any) declared available and suitable for satisfying accelerate-stop distance requirements for a rejected takeoff. Additional RSA and ROFA can be obtained by reducing the ASDA. Reference AC 150/5300-13A, Paragraph 323(d)(3).	X			
4. Landing Distance Available (LDA)	5300-13A List the length of runway declared available and suitable for satisfying landing distance requirements. The LDA may be reduced to satisfy the approach RPZ, RSA, and ROFA requirements. Reference AC 150/5300-13A, Paragraph 323(e).	X			
G. Legend	Provide a Legend that identifies all symbols and line types used on the drawing. Lines must be clear and readable with sufficient scale and quality to discern details.	X			
Remarks					

A.1. Airport Layout Plan Drawing

- For smaller airports, some of the ALP sheets may be combined if practical and approved by FAA.
- Two, or more, sheets may be necessary for clarity, existing and proposed. The reviewer should be able to differentiate between existing, future, and ultimate development. If clarity is an issue, some features of this drawing may be placed in tabular format. North should be pointed towards the top of the page or to the left. (scale 1"=200' to 1"=600')

Item	Instructions	Sponsor/Consultant			FAA
		Yes	No	N/A	
A. Title and Revision Blocks	Each drawing in the Airport Layout Plan drawing set shall have a Title and Revision Block. For drawings that have been updated, e.g., as-builts, the revision block should show the current revision number and date of revision.	X			
B. Space for the FAA approval stamp	Leave a blank four-inch by four-inch area for the FAA approval stamp.	X			
C. Layout of existing and proposed facilities and features:	To assure full consideration of future airport development in 14 CFR Part 77 studies, airport owners must have their plans on file with the FAA. The necessary plan data includes, as a minimum, planned runway end coordinates, elevation, and type of approach for any new runway or runway extension. See AC 150/5300-13A, Paragraph 106.	X			
1. True and magnetic North arrow with year of magnetic declination	Magnetic declination may be calculated at http://www.ngdc.noaa.gov/geomag-web/#declination . This model is using the latest World Magnetic Model which has an Epoch Year of 2010. See FAA Order 8260.19, "Flight Procedures and Airspace." Chapter 2, Section 5, for further information.	X			
2. Airport reference point – locate by symbol a Lat./Long. To nearest second (existing, future,	List the Airport Reference Point, the latitude and longitude of the approximate center of the airport. Use the NAD 83 coordinate	X			

and ultimate) NAD 83	system. See AC 150/5300-13A, Paragraph 207.				
3. Wind cones, segmented circle, beacon, AWOS, etc.	Show as applicable pursuant to AC 150/5300-13A, Chapter 6.	X			
4. Contours (showing only significant terrain differences)	Topography, budget, and future uses of the base mapping, will dictate what intervals of topographical contours to use on the maps. Topographic issues may be important in the alternatives analysis, which may require that reduced contour intervals be used. See AC 150/5070-6, 1005.	X			
5. Elevations: All NAVD88	All latitude/longitude coordinates shall be in NAD83/NAVD88.	X			
a. Runway – existing, future, and ultimate ends (nearest 0.1 ft.)	Show the latitude and longitude of the threshold center and end of pavement.	X			
b. Touchdown Zone Elevation (highest point in first 3,000 ft. of runway)	List the highest runway centerline elevation in the existing and ultimate first 3000 feet from landing threshold. See FAA Order 8260.3, Appendix 1.	X			
c. Runway high/low points (existing and future)	For all runways identify high and low points (centerline) and provide elevation information.	X			
d. Label runway/runway intersection elevations	Label the pavement elevation of runway intersections where the centerlines cross.			X	
e. Displaced Thresholds (if any)	Label the pavement elevation and coordinates of the runway pavement at any displaced threshold. See AC 150/5300-13A, Paragraph 303(a)(2).			X	
f. Roadways & Railroads (where they intersect Approach surfaces, the extended runway centerline, and at the most critical points)	Provide elevation information for the traverse ways' centerline elevation where they intersect the Part 77 Approach surfaces (existing and ultimate). Note whether this elevation is the actual elevation or the traverseway elevation plus the traverseway adjustment (23' for railways, 17' for interstate highways, 15' for other public roads, or 10' for private roads).	X			

	See also 14 CFR Part 77.				
g. Structures, Buildings, and Facilities	All buildings on the Airport Layout Drawing should be identified by an alphanumeric character. List these identifiers in a table and give a description of the building. If no Terminal Area drawing is done, also include the top of structure elevation in MSL. If any of the structures violate any airport or approach surfaces give an ultimate disposition to remedy the violation. Don't forget navigation aid shelters, AWOS/ASOS, RVRs, PAPIs, Fueling systems, REILs, etc. Also identify the structure use (hangar, FBO, crew quarters, etc.), as needed. Some lesser objects may be identified by symbols in the legend.	X			
h. Define features to include: trees streams, water bodies, etc.	Provide information and delineate trees, streams, water bodies, etc., on or near airport property and approach surfaces.	X			
6. Runway Details		X			
a. Runway Design – runway length, runway width, shoulder width, blast pad width, blast pad length, and cross wind component. (existing, future, and ultimate)	AC 150/5325-4 describes procedures for establishing the appropriate runway length. AC 150/5300-13A, Table 3-4 and Table 3-5 provides the minimum runway length. AC 150/5300-13A, Table 3-8 provides the standard dimensions of the runway width, shoulder width, blast pad width, blast pad length, and crosswind component based on RDC. Clearly denote the runway numbers at the thresholds. Show location of existing and future threshold lights.	X			
b. Orientation – true bearing to nearest 0.01 second (and runway numbers)	Show the true bearing to the nearest .01 of a degree of the runway centerline.	X			
c. End Coordinates – existing, future, and ultimate degrees,	Show the latitude and longitude of the threshold center and end of pavement (if different) to the	X			

	minutes, seconds (to the nearest 0.01 second)	nearest .01 of a second.				
d.	Runway Safety Areas (RSA) – actual, existing, future, and ultimate (including dimensions)	Show the extents of the existing and ultimate RSA 5300-13A. Reference AC 150/5300-13A, Paragraph 307.	X			
e.	Runway Object Free Areas (ROFA)	Show the extents of the existing and ultimate ROFA. Reference AC 150/5300-13A, Paragraph 309.	X			
f.	Precision Obstacle Free Zone (POFZ)	Show the extents of the existing and ultimate POFZ. Reference AC 150/5300-13A, Paragraph 308(d).	X			
g.	Obstacle Free Zone (OFZ)	Show the extents of the existing and ultimate OFZ. Reference AC 150/5300-13A, Paragraph 308.	X			
h.	Clearways and Stopways	Show any/all clearways and stopways/overruns and the markings used to denote these areas. See AC 150/5300-13A, Paragraph 311 and 312; and AC 150/5340-1, Section 2, Paragraph 14.	X			
i.	Runway Protection Zone (RPZ) - Dimensions (existing, future, and ultimate)	Show existing and ultimate RPZ. See AC 150/5300-13A, Paragraph 310. Show the existing and ultimate protective area/zone type of ownership. Identify any incompatible objects and activities inside the RPZ. Prior to including new or modified land use in the RPZ, the Regional and ADO staff must consult with the National Airport Planning and Environmental Division, APP-400. This policy is exempt from existing land uses in the RPZ. See AC 150/5300-13A, Paragraph 310 and FAA memorandum dated September 27, 2012.	X			
j.	14 CFR Part 77 Approach Surfaces	Show the portion of the existing and ultimate approach surfaces that are over airport and adjacent property and identify the approach surface dimensions and slope. See FAA Order	X			

	7400.2, Figure 6-3-9.				
k. Threshold Siting Criteria: Approach/Departure Surface (existing, future, and ultimate) 5300-13A	Determine and identify pursuant to AC 150/5300-13A, Paragraph 303(b) and 303(c).	X			
l. Terminal Instrument Procedures (TERPS)surface and TERPS GQS, if applicable.	Determine and identify pursuant to AC 150/5300-13A, Paragraph 303(a)(4)(a), Table 3-4, and Table 3-5. Reference FAA Order 8260.3.	X			
m. Navigation Aids (NAVAIDS) – PAPI, ILS, GS, LOC, ALS, MALSR, REIL, etc., (plus facility critical area's)	Show all NAVAIDS and provide clearance distances from runways, taxiways, etc. Reference AC 150/5300-13A, Chapter 6.	X			
n. Marking – thresholds, hold lines, etc.	Show on the runway the type and location of markings, existing and ultimate. See AC 150/5340-1, Section 2.	X			
o. Displaced threshold coordinates and elevation	Show the latitude, longitude, and the pavement elevation of the runway pavement at any displaced threshold. See AC 150/5300-13A, Paragraph 303(a)(2).5300-13A.			X	
p. Runway centerline separation distances	Show the runway centerline separation distances to parallel runway centerline, holding position, parallel taxiway/taxilane centerline, aircraft parking area, and helicopter touchdown pad, if applicable. Reference AC 150/5300-13A, Paragraph 321 and Table 3-8.	X			
7. Taxiway Details	Show the taxiway centerline separation distances to parallel taxiway/taxilane centerlines, fixed or movable objects.	X			
a. Dimensions – width (existing & ultimate)	Taxiway width based on Taxiway Design Group (TDG). See AC 150/5300-13A, Table 4-2.	X			
b. Taxiway Edge Safety Margin (TESM)	TESM dimension based on TDG. See AC 150/5300-13A, Table 4-2.	X			

c. Taxiway Shoulder Width	Taxiway shoulder width based on TDG. See AC 150/5300-13A, Table 4-2.	X			
b. Taxiway/Taxilane Object Free Area (TOFA)	TOFA width based on Taxiway Design Group (TDG). TOFA extend the entire length of taxiway. See AC 150/5300-13A, Table 4-1.	X			
c. Taxiway/Taxilane Safety Area (TSA)	TSA width based on TDG. TSA extend the entire length of taxiway. See AC 150/5300-13A, Table 4-1.	X			
d. Taxiway/Taxilane Centerline Separation from:		X			
i. Runway centerline	Show the distance from centerline of runway to centerline of taxiway. See AC 150/5300-13A, Table 4-1.	X			
ii. Parallel taxiway	Show the distance from centerline of taxiway to centerline of parallel taxiway. See AC 150/5300-13A, Table 4-1.	X			
iii. Aircraft parking	Show the distance from centerline of taxiway to marked aircraft parking/tie downs. See AC 150/5300-13A, Table 4-1.	X			
iv. Fixed or Movable Objects	Show the distance from centerline of taxiway to airport objects such as buildings, facilities, poles, etc. See AC 150/5300-13A, Table 4-1.	X			
8. Fences (identify height)	Show the location of existing and ultimate fences and identify height.		X		
9. Aprons					
a. Dimensions (square footage, dimension, or length and width)	Include dimensions of apron and distance from runway and taxiway centerlines. Apron should be sized using activity forecast and the apron design spreadsheet. See AC 150/5300-13A, Chapter 5 and FAA Engineering Brief No. 75.		X		

b. Identify aircraft tie-down layout	Show proposed tie-down layout on the apron area. See AC 150/5300-13A, Figure A5-1, AC 20-35, and AC 150/5340-1.			X	
c. Identify Special Use Areas (e.g., deicing or aerial application areas on or near apron)	Show as applicable and pursuant to representative ACs.			X	
10. Roads	Label all roads.	X			
11. Legend	Provide a Legend that identifies all symbols and line types used on the drawing. Lines must be clear and readable with sufficient scale and quality to discern details.	X			
12. Items to be identified with distinct line types	Use distinct line types to identify different items and differentiate between existing and ultimate.				
a. NAVAID Critical Areas (Glide Slope, Localizer, AWOS, ASOS, VOR, RVR, etc.)	Show the critical area outline for all Instrument Landing System and other electronic Navigational Aids located on the airport. See AC 150/5300-13A, Chapter 6 for general guidance and FAA Order 5750.16 for critical area dimensions.	X			
b. Building Restriction Lines 5300-13A(BRL)	The BRL is the line indicating where airport buildings must not be located, limiting building proximity to aircraft movement areas. See AC 150/5300-13A, Paragraph 213(a).	X			
c. Runway Visibility Zone (RVZ)	Show the RVZ for the existing and ultimate airport configurations. See AC 150/5300-13A, 305(c).			X	
d. Airport Property Lines and Easements (existing, future, and ultimate)	Show the airport property boundaries, including easements, for the existing and ultimate airport configurations.	X			
13. Survey Documentation					
a. Survey Monuments (PACS/SACS, see AC 150/5300-16)	Show the location of all established survey monuments located on or near the airport property. Identify Primary and			X	

	<p>Secondary Airport Control Stations (PACS/SACS) if they exist. See AC 150/5300-16.</p> <p>Show the location of all section corners on or near the airport property.</p>				
b. Offsets, stations, etc.	Show as applicable.			X	
14. Any Air Traffic Control Tower (ATCT) line of sight/shadow study areas (use separate sheet if necessary)	Reference FAA Order 6480.4.			X	
15. General Aviation development area (e.g., fuel facilities, FBO, hangars, etc.) – greater detail can be shown on the terminal area drawing	Show as applicable.	X			
16. Facilities and movement areas that are to be phased out, if any, are described	Show as applicable.	X			
Remarks					

A.2. Airport Airspace Drawing

- A required drawing.
- Scale 1” = 2000’ plan view, 1” = 1000’ approach profiles, 1”=100’ (vertical) for approach profiles.
- 14 CFR Part 77, Objects Affecting Navigable Airspace, defines this as a drawing depicting obstacle identification surfaces for the full extent of all airport development. It should also depict airspace obstructions for the portions of the surfaces excluded from the Inner Portion of the Approach Surface Drawing.

Item	Instructions	Sponsor/Consultant			FAA
		Yes	No	N/A	
A. Title and Revision Block	Each drawing in the Airport Layout Plan drawing set shall have a Title and Revision Block. For drawings that have been updated, e.g., as-builts, the revision block should show the current revision number and date of revision.	X			
B. Plan view (based on ultimate runway lengths) Include location of water or sewage facilities if inside horizontal surface.		X			
1. U.S. Geological Survey (USGS) Quad Sheet for base map	Use the most current USGS Quadrangle(s) as a base map for the airspace drawing.	X			
2. Runway end numbers	Show the ultimate runways and runway numbers. Contact the FAA before renumbering existing runways.	X			
3. Part 77 Surfaces (Horizontal, Conical, Transition, based on ultimate). Including elevations at the point where surfaces change.	Show the extents of the Part 77 imaginary surfaces. For airports that have precision approach runways show balance of the 40,000’ approach on a second sheet, if necessary. See 14 CFR Part 77.19.	X			
4. 50’ elevation contours on sloping surfaces (NAVD88)	Show contour lines on all sloping Part 77 imaginary surfaces. See 14 CFR Part 77.19.	X			
5. Top elevations of penetrating objects for the inner portion of the approach surface drawing	Identify by unique alphanumeric symbol all objects beyond the Runway Protection Zones that penetrate any of the Part 77 surfaces. See 14 CFR Part 77.	X			

<p>6. Note specifying height restriction (ordinances/statutes)</p>	<p>List any local zoning restrictions that are in place to protect the airport and surrounding airspace. See AC 150/5190-4.</p>			<p>X</p>	
<p>7. North Arrow with magnetic declination and year</p>	<p>Magnetic declination may be calculated at http://www.ngdc.noaa.gov/geomagnetic-web/#declination. This model is using the latest World Magnetic Model which has an Epoch Year of 2010. See FAA Order 8260.19, "Flight Procedures and Airspace." Chapter 2, Section 5, for further information.</p>	<p>X</p>			
<p>C. Profile view</p>					
<p>1. Airport Elevation</p>	<p>List the Airport Elevation, the highest point on an airport's usable runway expressed in feet above mean sea level (MSL). Use NAVD88 datum. See AC 150/5300-13A, Chapter 1, Paragraph 102(g).</p>	<p>X</p>			
<p>2. Composite Ground Profile along extended Runway Centerline (Representing the composite profile, based on the highest terrain across the width and along the length of the approach surface)</p>	<p>Depict the ground profile along the extended runway centerline representing the composite profile, based on the highest terrain across the width and along the length of the approach surface.</p>	<p>X</p>			
<p>3. Significant objects (bluffs, rivers, roads, schools, towers, etc.) and elevations</p>	<p>Identify all significant objects (roads, rivers, railroads, towers, poles, etc.) within the approach surfaces, regardless of whether or not they are obstructions. Use the objects' same alphanumeric identifier that was used on the plan view.</p> <p>Identify the top elevations of all significant objects (roads, rivers, railroads, towers, poles, etc.) within the approach surfaces, regardless of whether or not they are obstructions.</p>			<p>X</p>	
<p>4. Existing, future, and ultimate runway ends and approach slopes</p>	<p>Show existing and ultimate runway ends and FAR Part 77 approach surface slopes. See 14</p>	<p>X</p>			

	CFR Part 77.19.				
D. Obstruction Data Tables (identify obstacles not depicted on the Inner Portion of the Approach Surface Drawing)					
1. Object identification number	<p>Identify all significant objects (roads, rivers, railroads, towers, poles, etc.) within the approach surfaces, regardless of whether or not they are obstructions. Use the objects alphanumeric identifier that was used on the plan view.</p> <p>Identify the top elevations of all significant objects (roads, rivers, railroads, towers, poles, etc.) within the approach surfaces, regardless of whether or not they are obstructions.</p>	X			
2. Description	Provide a brief description of the object, e.g., Power Pole, Cell Tower, Natural Gas Flare, etc.	X			
3. Date of Obstruction Survey	Provide the date of latest obstruction survey.	X			
4. Ground Surface Elevation	Provide the ground surface elevation (MSL) at the base of each object.			X	
5. Object Elevation	List the above ground level (AGL) height and the top of object elevation (above mean sea level / AMSL / MSL) for each object.	X			
6. Amount of surface penetration	List the surface that is penetrated and the amount the object protrudes above the surface. See 14 CFR Part 77.	X			
7. Proposed or existing disposition of the obstruction	Provide a proposed or existing disposition of the object to remedy the penetration. See AC 70/7460-1.				
a. Proposed Disposition (existing)		X			
b. Proposed Disposition (future)		X			

Effective Date: October 1, 2013

ARP SOP No. 2.00

Remarks

Inner Portion of the Approach Surface Drawing

- A required drawing.
- Scale 1”=200’ Horizontal, 1”=20’ Vertical, two sheets may be necessary for clarity. Typically, the plan view is on the top half of the drawing and the profile view is on the bottom half. Views should be drawn from the runway threshold to a point on the approach slope 100 feet above the runway threshold elevation, at a minimum, or the limits of the RPZ, whichever is further.
- Drawings containing the plan and profile view of the inner portion of the approach surface to the runway and a tabular listing of all surface penetrations. The drawing will depict the obstacle identification approach surfaces contained in 14 CFR Part 77, Objects Affecting Navigable Airspace. The drawing may also depict other surfaces, including the threshold-siting surface, Glideslope Qualification Surface (GQS), those surfaces associated with United States Standards for Instrument Procedures (TERPS), or those required by the local FAA office or state agency. The extent of the approach surface and the number of airspace obstructions shown may restrict each sheet to only one runway end or approach.

Item	Instructions	Sponsor/Consultant			FAA
		Yes	No	N/A	
A. Title and Revision Block	Each drawing in the Airport Layout Plan drawing set shall have a Title and Revision Block. For drawings that have been updated, e.g., as-builts, the revision block should show the current revision number and date of revision.	X			
B. Plan View (existing, future, and ultimate)					
1. Inner portion of approach surface	Show the area from the runway threshold out to where the ultimate approach surface slope is 100 feet above the threshold elevation.	X			
2. Aerial photo for base map	Use an aerial photograph for the base map.	X			
3. Objects (identified by numbers)	Identify all significant objects (roads, rivers, railroads, towers, poles, etc.) within the approach surfaces, regardless of whether or not they are obstructions using an alphanumeric character.	X			
4. Property line within approaches	Show the property lines that are within the area/portion of airport shown.	X			
5. Road & railroad	Provide elevation information for	X			

elevations, plus movable object heights	the traverse ways' centerline elevation where they intersect the Part 77 Approach surfaces (existing and ultimate). Note whether this elevation is the actual elevation or the traverse way elevation plus the traverse way adjustment (23' for railways, 17' for interstate highways, 15' for other public roads, or 10' for private roads). See also 14 CFR Part 77.				
6. Part 77 Approach Surface clearance over Roads and Railroads at the most critical points, the Centerline and Edge of the surface.	Provide elevation information for the traverse ways where they intersect the edges and centerline of the Part 77 Approach surfaces (existing and ultimate). Note whether this elevation is the actual elevation or the traverseway elevation plus the traverseway adjustment (23' for railways, 17' for interstate highways, 15' for other public roads, or 10' for private roads). See also 14 CFR Part 77.	X			
7. Physical end of runway, end number, elevation (NAVD88) Nearest 0.1 foot	Show the existing and ultimate runway end, runway number, and the elevation of the threshold center.	X			
8. Airport Design Surfaces					
a. Runway Safety Area	Show the extents of the existing and ultimate Runway Safety Area (RSA). See AC 150/5300-13A, Paragraph 307 and Table 3-8.	X			
b. Runway Object Free Area	Show the extents of the existing and ultimate Object Free Area (OFA). See AC 150/5300-13A, Paragraph 309 and Table 3-8.	X			
c. Runway Obstacle Free Zone (OFZ)	Show the extents of the existing and ultimate OFZ which includes the inner-approach OFZ, inner-transitional OFZ, and the Precision OFZ (POFZ), if applicable. See AC 150/5300-13A, Paragraph 308.	X			
d. Runway Protection Zone (RPZ)	Show the extents of the existing and ultimate RPZ. Prior to including new or modified land use in the RPZ, the Regional and ADO staff must consult with the National Airport Planning and	X			

	Environmental Division, APP-400. This policy is exempt from existing land uses in the RPZ. See AC 150/5300-13A, Paragraph 310, Table 3-5 and FAA memorandum dated September 27, 2012.				
e. NAVAID critical area	Show the critical area outline for all Instrument Landing System and other electronic Navigational Aids located on the airport. See AC 150/5300-13A, Chapter 6 for general guidance and FAA Order 5750.16 for critical area dimensions.	X			
9. Ground contours	Show ground contour lines in 2', 5', or 10' intervals. Topographic issues may be important in the alternatives analysis, which may require that reduced contour intervals be used. See AC 150/5070-6, Paragraph 1005.	X			
10. North arrow with magnetic declination and year	Magnetic declination may be calculated at http://www.ngdc.noaa.gov/geomagnetic-web/#declination . This model is using the latest World Magnetic Model which has an Epoch Year of 2010. See FAA Order 8260.19, Chapter 2, Section 5, for further information.	X			
C. Profile view					
1. Existing and proposed runway centerline ground profile (list elevations at runway ends & at all points of grade changes) (representing the composite profile based on the highest terrain across the width and along the length of the approach surface)	Depict the ground profile along the extended runway centerline representing the composite profile, based on the highest terrain across the width and along the length of the approach surface to where the ultimate approach surface slope is 100 feet above the threshold elevation. A more effective presentation may be a rendering of a composite critical profile.	X			
2. Future development from plan view	Identify future development using same alphanumeric identifier that was used on the plan view.			X	
3. Part 77 Approach/transition surface; existing and future VASI/PAPI siting	Show the boundaries of the existing and ultimate Part 77 Approach Surface. See FAA Order 7400.2, Figure 6-3-9, See	X			

surface	also 14 CFR Part 77.				
4. Threshold Siting Surface	Depict any applicable siting requirements pursuant to Table 3-2 of FAA AC 150/5300-13A.	X			
5. Terrain in approach area (fences, streams, etc.)	Show all significant terrain(fences, streams, mountains, etc.) within the approach surfaces, regardless of whether or not they are obstructions	X			
6. Objects – identify the controlling object (same numbers as plan view)	Show all significant objects (roads, rivers, railroads, towers, sign and power poles, etc.) within the approach surfaces, regardless of whether or not they are obstructions. Identify the objects using same alphanumeric identifier that was used on the plan view.	X			
7. Cross section of road & railroad	Show the cross-section of any roads and/or railroads that cross the area shown. Indicate cross section elevations of roads and railroads at edges and extended centerlines that cross the area shown.	X			
8. Existing and proposed property and easement lines	Show the airport property boundaries, including easements, for the existing and ultimate airport configurations. AC 5300-13A Note easements for pipelines and residential through the fence gateways.	X			
D. Obstruction tables for each approach surface (surface should be identified)	A separate table for each runway end must be used to enhance information clarity.				
1. Object identification number	List each object by the same alphanumeric symbol used in the plan view.			X	
2. Description	Provide a brief description of the object, e.g., Power Pole, Cell Tower, Natural Gas Flare, etc.			X	
3. Date of Obstruction Survey and Survey Accuracy	Provide the date of latest obstruction survey.			X	

4. Surface Penetrations	5300-13A For any object that penetrates the Part 77 surface, the approach surface, or the obstacle free zone, describe the vertical length the object protrudes.			X	
5. Proposed disposition of surface penetrations	Provide a proposed disposition of the object to remedy the penetration as described in item 4 above. See AC 70/7460-1 for Part 77 violations. "Removal" and/or "Lower" should be listed for any Airports safety area/zone violations. See AC 150/5300-13A, Paragraph 303 and 308.			X	
6. Object elevation	List the Above Ground Level (AGL) height and the top of object elevation in MSL for each object.			X	
7. Triggering Event (e.g., a runway extension) – Timeframe/expected date for removal	List the surface that is penetrated and the amount the object protrudes above the surface. See 14 CFR Part 77 and AC 150/5300-13A, Paragraphs 303 and 308.			X	
8. Allowable approach surface elevation (if applicable)				X	
9. Amount of approach surface penetration (if applicable)				X	
10. Proposed disposition of approach surface obstruction (if applicable)	Provide a proposed disposition of the object to remedy the penetration. See AC 70/7460-1 for Part 77 violations. "Removal" and/or "Lower" should be listed for any Airports safety area/zone violations. See AC 150/5300-13A, Paragraph 303.			X	
11. Obstacle Free Zone (OFZ)	Determine and depict the applicable OFZ surfaces, see AC 150/5300-13A, Paragraph 308. Provide a proposed disposition of the object to remedy the penetration. Note: Modification to the OFZ standard is not permitted.			X	
E. Runway Centerline Profile	This may be shown on the Inner Portion of the Approach Surface				

	drawing if there is space to show the runway and Runway Safety Area in sufficient detail otherwise a separate sheet may be necessary. At a minimum this drawing is to show the full length of the runway and Runway Safety Area including: runway elevations, runway and Runway Safety Area gradients, all vertical curves, and a line representing the 5' line-of-sight. See AC 150/5300-13A, Paragraph 305.				
1. Scale	The vertical scale of this drawing must be able to show the separation of the runway surface and the 5' Line-of-Sight line. See AC 150/5300-13A, Paragraph 305.	X			
2. Elevation	Show runway elevations, runway and Runway Safety Area gradients, and all vertical curve data. See AC 150/5300-13A, Paragraph 318.	X			
3. Line of Sight	The vertical scale of this drawing must be able to show the separation of the runway surface and the 5' Line-of-Sight line. See AC 150/5300-13A, Section 305.			X	
Remarks					

A.3. Runway Departure Surface Drawing

- Required where applicable. For each runway that is designated for instrument departures.
- This drawing depicts the applicable departure surfaces as defined in Paragraph 303 of FAA AC 150/5300-13A. The surfaces are shown for runway end(s) designated for instrument departures.
- 40:1 for Instrument Procedure Runways (Scale, 1” = 1000’ Horizontal, 1” = 100’ Vertical, Out to 10,200’ beyond Runway threshold) 62.5:1 for Commercial Service Runways (Scale, 1” = 2000’ Horizontal, 1” = 100’ Vertical, Out to 50,000’ beyond Runway threshold).
- Contact the FAA if the scale does not allow the entire area to fit on a single sheet. The depiction of the One Engine Inoperative (OEI) surface is optional; it is not currently required.

Item	Instructions	Sponsor/Consultant			FAA
		Yes	No	N/A	
A. Title and Revision Blocks	Each drawing in the Airport Layout Plan drawing set shall have a Title and Revision Block. For drawings that have been updated, e.g., as-builts, the revision block should show the current revision number and date of revision.			X	
B. Plan view (existing & future)	See AC 150/5300-13A, Paragraph 303(c).			X	
1. Aerial Photo for base map	Use an aerial photograph for the base map. A USGS 7.5 minute series map is also acceptable.			X	
2. Runway end numbers and elevations (nearest 1/10 of a foot)	Show the existing and ultimate runway end, runway number, and the elevation of the threshold center. For runways that have a clearway, depict this surface and the relocated departure surface. Reference AC 150/5300-13A, Paragraph 303(c)(1).			X	
3. 50’ elevation contours on sloping surfaces (NAVD88)	Show contour lines on the Part 77 imaginary surfaces. See 14 CFR Part 77.19.			X	
4. Depict property line, including easements	Show the property line(s) that are within the area/portion of airport shown.			X	
5. Identify, by numbers, all traverse ways with elevations and computed	Identify all significant objects (roads, rivers, railroads, towers, poles, etc.) within the departure			X	

vertical clearance in the departure surface	surfaces, regardless of whether or not they are obstructions using unique alphanumeric characters.				
6. Ground contours	Show ground contour lines in 2', 5', or 10' intervals. Topographic issues may be important in the alternatives analysis, which may require that reduced contour intervals be used.			X	
C. Profile view (existing & future)				X	
1. Ground profile	Depict the ground profile along the extended runway centerline representing the composite profile, based on the highest terrain across the width and along the length of the departure surface to extents of the surface dimensions.			X	
2. Significant objects (bluffs, rivers, roads, buildings, fences, structures, etc.)	Show all significant objects (roads, rivers, railroads, towers, poles, etc.) within the approach surfaces, regardless of whether or not they are obstructions using an alphanumeric character.			X	
3. Identify obstructions with numbers on the plan view	Identify the objects using same alphanumeric identifier that was used on the plan view.			X	
4. Show roads and railroads with dashed lines at edge of the departure surface	Show the cross-section of any roads and/or railroads that cross the area shown.			X	
D. Obstruction Data Tables					
1. Object identification number	Identify all significant objects (roads, rivers, railroads, towers, poles, etc.) within the departure surfaces, regardless of whether or not they are obstructions using unique alphanumeric characters. List each object by the same alphanumeric symbol used in the plan view.			X	
2. Description	Provide a brief description of the object, e.g., Power Pole, Cell Tower, Tree, Natural Gas Flare, etc.			X	
3. Object Elevation	List the Above Ground Level (AGL) height and the top of object elevation in MSL for each			X	

	object.				
4. Amount of surface penetration	List the object protrudes above the departure surface. See AC 150/5300-13A, Paragraph 303(c).			X	
5. Proposed or existing disposition of the obstruction	Provide a proposed disposition of the object to remedy the penetration. See AC 150/5300-13A, Paragraph 303(c).			X	
6. Separate table for each departure surface	A separate table for each runway end must be used to enhance information clarity.			X	
Remarks					

A.4. Terminal Area Drawing

- Scale 1”=50’ or 1”=100’. Plan view of aprons, buildings, hangars, parking lots, roads.
- This plan consists of one or more drawings that present a large-scale depiction of areas with significant terminal facility development. Such a drawing is typically an enlargement of a portion of the ALP. At a commercial service airport, the drawing would include the passenger terminal area, but might also include general aviation facilities and cargo facilities. See AC 150/5300-13A, Appendix 5.
- Use scale that allows the extent of the terminal/FBO apron area to best fit the chosen sheet size, e.g., typical GA airports may be able to use 1”=50’ scale on a 22” X 34” sheet, but a complex hub airport with multiple terminal areas may require a 1”=100’ scale on a 36” X 48” sheet. Contact FAA if an airport layout requires scaling or sheet sizing other than what is listed.
- This drawing is not needed at every airport type and is therefore optional.

Item	Instructions	Sponsor/Consultant			FAA
		Yes	No	N/A	
A. Title and Revision Blocks	Each drawing in the Airport Layout Plan drawing set shall have a Title and Revision Block. For drawings that have been updated, e.g., as-builts, the revision block should show the current revision number and date of revision.			X	
B. Building data table	All buildings on the Airport Layout Drawing should be identified by an alphanumeric character. List these identifiers in a table and give a description of the building. If no Terminal Area drawing is done, also include the top of structure elevation in MSL.			X	
1. Structure identification number				X	
2. Top elevation of structures (AMSL)				X	
3. Obstruction marking/lighting (existing/future)		Show the location of existing and ultimate hangars. Include dimensions of apron and distance from runway and taxiway centerlines. See AC 150/5300-13A, Appendix 5. Show the elevation of the highest point of each structure.			X
C. Buildings to be removed or relocated noted	If any of the structures violate any airport or approach surfaces give an ultimate disposition to remedy the violation.			X	

D. Fueling facilities, existing and future	Show the location of existing and ultimate fueling facilities. Include dimensions of apron and distance from runway and taxiway centerlines.			X	
E. Air carrier gates positions shown (existing/future)	Show the existing and ultimate air carrier gate positions. See AC 150/5300-13A, Chapter 5.			X	
F. Existing and future security fencing with gates	Show the existing and ultimate security fencing and gates. See AC 150/5300-13A, Paragraph 606.			X	
G. Building restriction line (BRL)	Show the Building Restriction Line (BRL) that is within the area/portion of airport shown. The BRL identifies suitable building area locations on airports. This should be located where the Part 77 surfaces are at 35' above the airport elevation unless a different height is coordinated with the FAA. See AC 150/5300-13A, Paragraph 213(a).			X	
H. Taxiway or Taxilane centerlines designated	Show centerlines of all taxiway and taxilanes within the area/portion of airport shown.			X	
I. Dimensions				X	
1. Clearance Dimensions between runway, taxiway, and taxilane centerlines and hangars, buildings, aircraft parking, and other objects.	Show the location of existing and ultimate apron. Include dimensions of apron and distance from runway and taxiway centerlines. Apron should be sized using activity forecast and the apron design spreadsheet. See AC 150/5300-13A, Chapter 5 and FAA Engineering Brief No. 75.			X	
2. Dimensions of aprons, taxiways, etc. Apron/Hangar areas that do not meet dimensional standards of the critical aircraft should be identified and the wingspan/design group of the aircraft that can use that area depicted. Include tie down location with clearances	Show the dimensions between existing and ultimate runway, taxiway, and taxilane centerlines and existing and ultimate hangars, buildings, aircraft parking, and other fixed or movable objects. See AC 150/5300-13A, Chapter 3 and Chapter 4. Show proposed tie-down layout on the apron area as well as taxilane marking plan. See AC			X	

	150/5300-13A, Appendix 5, AC 20-35, and AC 150/5340-1.				
J. Property Line	Show the property line(s) that are within the area/portion of airport shown.			X	
K. Auto parking (existing & ultimate)	Show the existing and ultimate auto parking areas. See AC 150/5300-13A, Appendix 5.			X	
L. Major airport drainage ditches or storm sewers	Show any significant airport drainage ditches or storm sewers within the area/portion of airport shown.			X	
M. Special Use Area (e.g., Agricultural spraying support, Deicing, or Containment)	Show any special use areas within the area/portion of airport shown.			X	
N. North Arrow with magnetic declination and year	Magnetic declination may be calculated at http://www.ngdc.noaa.gov/geomagnetic-web/#declination . This model is using the latest World Magnetic Model which has an Epoch Year of 2010. See FAA Order 8260.19, "Flight Procedures and Airspace." Chapter 2, Section 5, for further information.			X	
O. Fence	Show the existing and ultimate perimeter fencing or general area fencing.			X	
P. Entrance Road	Show the existing and ultimate entrance road. See 5300-13AFAA Order 5100.38, Chapter 6, Section 2.			X	
Remarks					

A.5. Land Use Drawing

- Scale 1"=200' to 1"=600'.
- A drawing depicting on- and off-airport land uses and zoning in the area around the airport. At a minimum, the drawing must contain land within the 65 DNL noise contour. For medium or high activity commercial service airports, on-airport land use and off-airport land use may be on separate drawings. The Airport Layout Drawing should be used as a base map.
- Drawing optional. Need based on scope of work.

Land Use Drawing					
Item	Instructions	Sponsor/Consultant			FAA
		Yes	No	N/A	
A. Title and Revision Blocks	Each drawing in the Airport Layout Plan drawing set shall have a Title and Revision Block. For drawings that have been updated, e.g., as-builts, the revision block should show the current revision number and date of revision.	X			
B. Airport boundaries/property, existing & future (fee and easement)	Show the existing and ultimate property lines. If known, show property lines for parcels surrounding the airport.	X			
C. Plan view of land uses by category (Agricultural, Aeronautical, Commercial, Residential, etc.). Use local land use categories.		X			
1. On-Airport (existing & future)	Label existing and ultimate on-airport property by usage, e.g., Terminal Area, Air Cargo, Public Ramp, Airfield - Movement, Airfield - Non-movement, etc. Include existing and future airport features (e.g., runways, taxiways, aprons, safety areas/zones, terminal buildings and navigational aids).	X			
2. Off-Airport (existing & future) [to the 65 DNL Contour at a minimum, if contour known]	Label existing and ultimate off-airport property by usage and zoning, e.g., Agricultural, Industrial, Residential, Commercial, etc.	X			
D. Boundaries of local government	List any local zoning restrictions that are in place to protect the airport and surrounding airspace. See AC 150/5190-4.			X	

E. Land use legend	Provide a legend that identifies all symbols and line types used on the drawing. Lines must be clear and readable with sufficient scale and quality to discern details.	X			
F. Public facilities (schools, hospitals, parks, churches etc.)	Identify public facilities, e.g., schools, parks, etc.			X	
G. Runway visibility zone for intersecting runways	Show the Runway Visibility Zone(s) for the existing and ultimate airport configurations. See AC 150/5300-13A, Section 305.			X	
H. Show off-airport property out to 65 DNL if available	Label existing and ultimate off-airport property by usage and zoning, e.g., Agricultural, Industrial, Residential, Commercial, etc.			X	
I. Airport Overlay Zoning or Zoning Restrictions	List any local zoning restrictions that are in place to protect the airport and surrounding airspace. See AC 150/5190-4.			X	
J. North arrow with magnetic declination and year	Magnetic declination may be calculated at http://www.ngdc.noaa.gov/geomagnetic-web/#declination . This model is using the latest World Magnetic Model which has an Epoch Year of 2010. See FAA Order 8260.19, "Flight Procedures and Airspace." Chapter 2, Section 5, for further information.	X			
K. Drawing details to include runways, taxiways, aprons, RPZ, terminal buildings and NAVAIDS	Show existing and future airport features (e.g., runways, taxiways, aprons, safety areas/zones, terminal buildings and navigational aids, etc.). See AC 150/5300-13A.	X			
L. Crop Restrictions	Show the Crop Restriction Line (CRL). See AC 150/5300-13A, Paragraph 322 and AC 150/5200-33.			X	
Remarks					

Effective Date: October 1, 2013

ARP SOP No. 2.00

--

- Scale 1"=200' to 1"=600'.

Item	Instructions	Sponsor/Consultant			FAA
		Yes	No	N/A	
A. Will Property Map serve as Exhibit A? <ul style="list-style-type: none"> – If YES, follow the directions to the right. – If NO, go to item B below. 	If prepared in accordance with AC 150/5100-17, Land Acquisition and Relocation Assistance for Airport Improvement Program Assisted Projects, use ARP SOP no. 3.00 Exhibit A guidance instead of below checklist.			X	
If Property Map will not serve as Exhibit A: B. Title and Revision Blocks				X	
C. Plan view showing parcels of land (existing, future, and ultimate)				X	
1. Fee land interests (existing and future)				X	
2. Easement interests (existing and future)				X	
a. Part 77 protection				X	
b. Compatible Land Use				X	
c. RPZ protection				X	
3. Airport Property Line				X	
D. Legend – shading/cross hatching, survey monuments, etc.				X	
E. Data Table					
1. Depiction of various tracts of land acquired to develop airport	If any obligations were incurred as a result of obtaining property, or an interest therein, they should be noted. Obligations that stem from Federal grant or an FAA-administered land transfer program, such as surplus property programs, should also			X	

Effective Date: October 1, 2013

ARP SOP No. 2.00

	be noted. The drawing should also depict easements beyond the airport boundary.				
2. Method of acquisition or property status (fee simple, easement, etc.)				X	
3. Type of Acquisition Indicated	(e.g., AIP-noise, AIP-entitlement, PFC, surplus property, local purchase, local donation, condemnation, other)			X	
4. Acreage				X	
F. Access point(s) for through-the-fence arrangements including residential				X	
Remarks					

Appendix B 2017 Airport Layout Plan Set

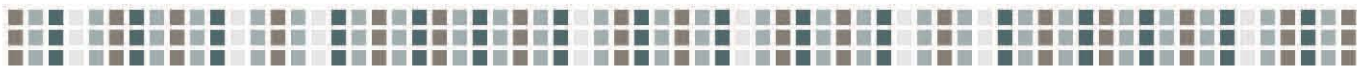

AIRPORT LAYOUT PLAN FOR DADE-COLLIER TRAINING AND TRANSITION AIRPORT (TNT) MIAMI, FL MIAMI-DADE AVIATION DEPARTMENT DECEMBER 2017



LOCATION MAP
NTS



VICINITY MAP
NTS

Emilio González, Aviation Director
Miami-Dade Board of County Commissioners
<http://www.miamidade.gov/commission/>

- District 1 - Barbara J. Jordan
- District 2 - Jean Monestime
- District 3 - Audrey Edmonson
- District 4 - Sally A. Heyman
- District 5 - Bruno A. Barreiro
- District 6 - Rebeca Sosa
- District 7 - Xavier L. Suarez
- District 8 - Daniella Levine Cava
- District 9 - Dennis C. Moss
- District 10 - Javier D. Souto
- District 11 - Joe A. Martinez
- District 12 - José "Pepe" Diaz
- District 13 - Esteban Bovo, Jr

DRAWING INDEX	
SHEET	SHEET TITLE
01	COVER SHEET
02	AIRPORT DATA SHEET
03	EXISTING & FUTURE AIRPORT LAYOUT PLAN
04	AIRPORT AIRSPACE DRAWING
05	INNER PORTION OF THE APPROACH DRAWING
06	LAND USE DRAWING
07	AIRPORT PROPERTY MAP

FDOT Approval	
Florida Department of Transportation _____	Date _____
Airport Approval	
Training and Transition Airport On behalf of Miami-Dade Aviation Department, I hereby certify that the TNT Airport Layout Plans Package was prepared according to the FAA Region Checklist as provided by the FAA Airport District Office.	
Jose Ramos, RA LEED AP Division Director, Aviation Planning, Land Use & Grants	Date _____

Revision Description	Date	Name

File: 01 COVER SHEET.dwg Layout: 24x36 COVER SHEET (bottom) Last Saved: 4/2/2018 10:53 AM Printed on: 4/2/2018 10:54 AM User: jda L1 Scale: 0.6000

jacobsondaniels associates, llc
121 Pearl St.
Ypsilanti, MI 48197
(734) 961-3200

RICONDO & ASSOCIATES
1000 N.W. 57th Court
Suite 920
Miami, Florida 33126-3511
(305) 260-2727

AIRPORT DATA		
ITEM	EXISTING	FUTURE
Airport Reference Code	D-V	Same
Mean Max Temperature of Hottest Month	93.8 (August)	Same
Airport Elevation (NAVD 88)	13.0 ft.	Same
Airport Reference Point	Latitude	(N) 25° 51' 42"
	Longitude	(W) 80° 53' 49"
	Datums	NAD 83, NAVD 88
Airport Navigational Aids	Beacon, NDB, GPS	Same
Miscellaneous Facilities	Lighted Wind Cone, Taxiway Lights	Same
Critical Aircraft	B-747	Same
Airport Magnetic Variation	Declination	5° 55' 44" (W)
	Annual Change	6.0' (W)
	Date	MAY 2014
	Source	NGS Data Center NOAA
NPIAS Service Level	General Aviation	Same
State Service Level	General Aviation	Same

Notes:
Source:
National Oceanic And Atmospheric Administration (NOAA)
National Climatic Data Center (NCDC)
U.S. Department of Commerce
Asheville, North Carolina

Observation Station: Miami International Airport, Miami FL
Period of Record: 10 years (January 2005 to January 2014)
Number of Observations: 78,907

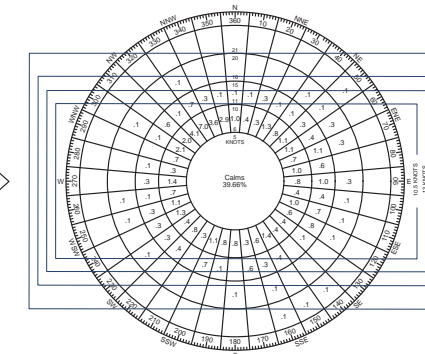
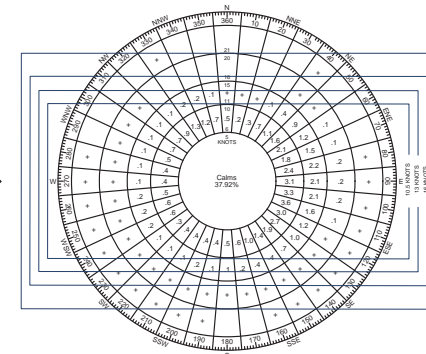
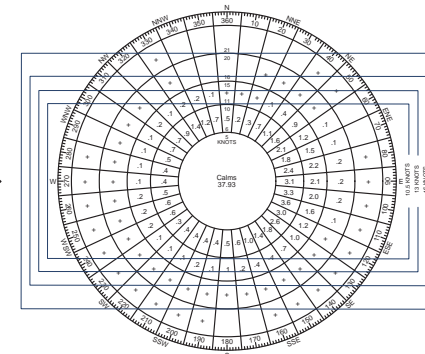

WIND COVERAGE ALL WEATHER CONDITIONS		
CROSSWIND COMPONENT	RWY 9	RWY 27
10.5 KTS	91.67%	59.63%
	97.90%	
13 KTS	93.15%	60.90%
	96.3%	
16 KTS	93.35%	61.07%
	99.85%	
20 KTS	93.44%	61.17%
	99.98%	

WIND COVERAGE VFR CONDITIONS		
CROSSWIND COMPONENT	RWY 9	RWY 27
10.5 KTS	91.74%	59.45%
	97.93%	
13 KTS	93.22%	60.70%
	99.61%	
16 KTS	93.41%	60.87%
	99.85%	
20 KTS	93.49%	60.96%
	99.98%	

WIND COVERAGE IFR CONDITIONS		
CROSSWIND COMPONENT	RWY 9	RWY 27
10.5 KTS	83.52%	81.42%
	95.39%	
13 KTS	85.75%	83.80%
	98.32%	
16 KTS	86.31%	84.50%
	99.16%	
20 KTS	86.73%	84.64%
	99.58%	

RUNWAY DATA		
ITEM	EXISTING & FUTURE RUNWAY 9 / 27	
	R/W 9	R/W 27
Runway Design Code (RDC)	D/VI/5000	D/VI/5000
Approach Reference Code (APRC)	D/VI/5000	D/VI/5000
Departure Reference Code (DRC)	D/VI	D/VI
Runway End Coordinates	Latitude	25° 51' 42.4939"
	Longitude	W 80° 54' 46.6351"
Runway End Elevations	12.6	12.4
	Runway Length	10,499
Runway Width	150	
Runway Bearing (True)	90° 01' 48"	270° 03' 00"
Displaced Threshold Coordinates	Latitude	N/A
	Longitude	N/A
	Elevation	N/A
Touchdown Zone Elevation (TDZE)	12.7	12.6
Pavement Material / Treatment	ASPH / GRVD	
Runway Pavement Strength (x 1,000 LBS)	S - 130 / D - 200 / DT - 400 / DDT - 800	
Runway Pavement Strength By PCN	65/F/A/X/T	
Maximum Effective Gradient (%)	0.0%	0.0%
Percent Wind Coverage	10.5 Knots	91.67%
	13 Knots	93.15%
	16 Knots	93.35%
	20 Knots	93.44%
Visibility Minimums	1-MILE	3-MILES
FAR Part 77 Approach Type	Non-Precision	Visual
FAR Part 77 Approach Category	34:1	20:1
TERPS Departure Surface / OCS	N/A	N/A
Threshold Sighting Surface	20:1	20:1
Runway Safety Area Length 1	1,000	1,000
Runway Safety Area Width	500	500
Runway Object Free Area Length 1	1,000	1,000
Runway Object Free Area Width	800	800
Approach Runway Protection Zone (W1 x W2 x L)	500 x 1,010 x 1,700	500 x 1,010 x 1,700
Departure Runway Protection Zone (W1 x W2 x L)	N/A	N/A
Runway Object Free Zone Length (G)1	200	200
Runway Object Free Zone Width (D)	400	400
Precision Obstacle Free Zone Length 1	N/A	N/A
Precision Obstacle Free Zone Width	N/A	N/A
Inner-Approach Obstacle Free Zone Length (G)2	2,400	N/A
Inner-Approach Obstacle Free Zone Width (D)	400	N/A
Inner-Transitional Obstacle Free Zone Horizontal Surface Elevation	N/A	N/A
Inner-Transitional Obstacle Free Zone (H)	N/A	N/A
Inner-Transitional Obstacle Free Zone (Y)	N/A	N/A
Runway Lighting	HIRL	HIRL
Runway Marking	PRECISION	PRECISION
Visual Approach Aids	MALSR	PAPI(P4L)
Instrument Approach Aids	DME, NDB, GPS	N/A
Aeronautical Survey Required for Approach	VGS	NVGS

TAXIWAY DATA							
Name	Width				Objects Inside TSA and TOFA	Separation From TWY CL to Fixed/Movable Object	Taxiway / Taxilane Lighting
	Taxiway	Shoulder	TSA	OFA			
Ex. Taxiways	75	25	214	320	None	N/A	MITL
Fut. Taxiways	75	30	214	320	None	N/A	MITL

DECLARED DISTANCE						
ITEM	RUNWAY		9		27	
	Existing	Future	Existing	Future	Existing	Future
Take Off Run Available (TORA)	10,499	Same	10,499	Same	10,499	Same
Take Off Distance Available (TODA)	10,499	Same	10,499	Same	10,499	Same
Accelerate Stop Distance Available (ASDA)	10,499	Same	10,499	Same	10,499	Same
Landing Distance Available (LDA)	10,499	Same	10,499	Same	10,499	Same

All Dimensions are in feet.
All Elevations are in feet above mean sea level (AMSL)
1 Distance is measured prior to the physical end of pavement in the direction of travel
2 Distance is measured 200' prior to the runway threshold and extends 200' beyond the last light unit in the ALS

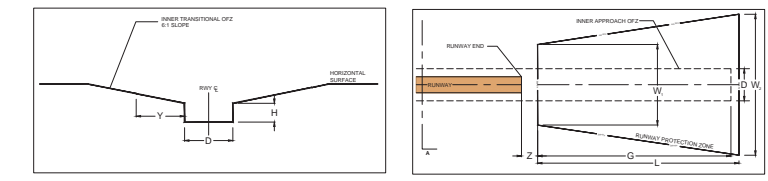

Declination: 05°55'44" W (2014)
Changing: 6.0' W per Year

Revision and Description	Date	Name

AIRPORT DATA SHEET

DADE-COLLIER TRAINING AND TRANSITION AIRPORT
AIRPORT LAYOUT PLANS UPDATE

TNT
Drawn by: CLJ
Checked By: JEK
Issue Date: DECEMBER 2017
Sheet: 2 OF 7

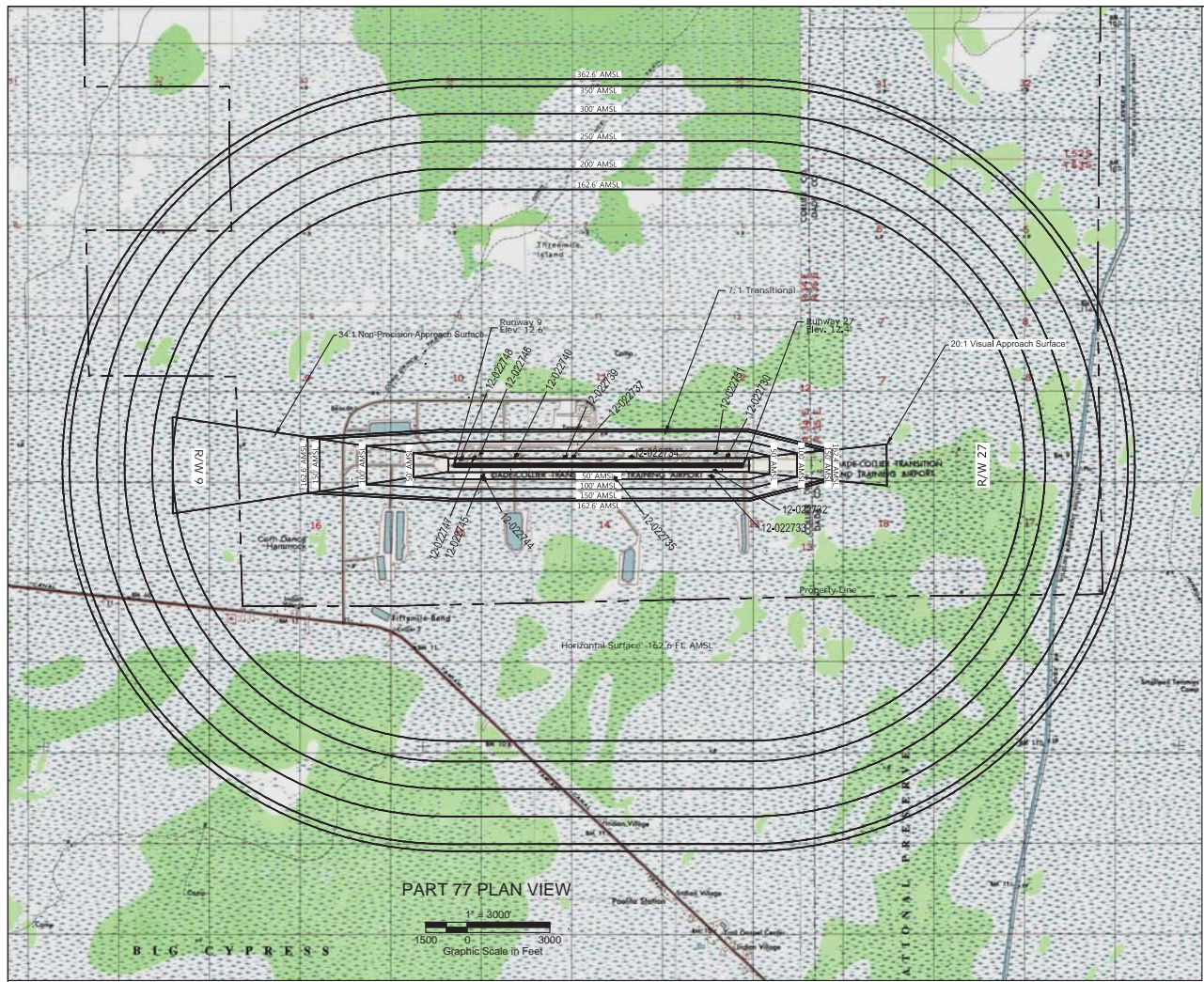

VIEW OF IMAGINARY SURFACES

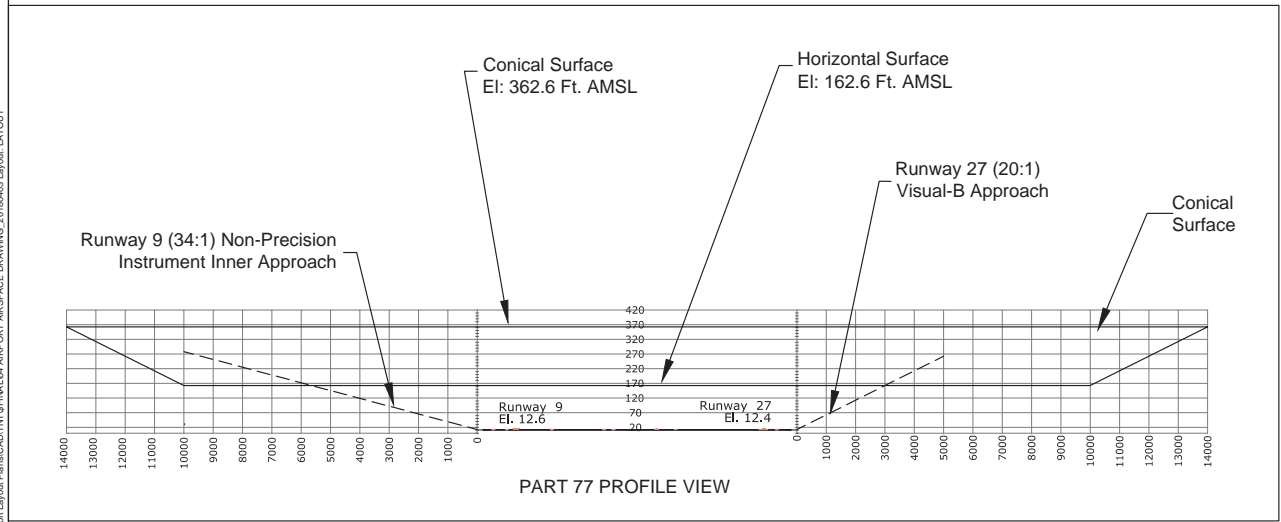
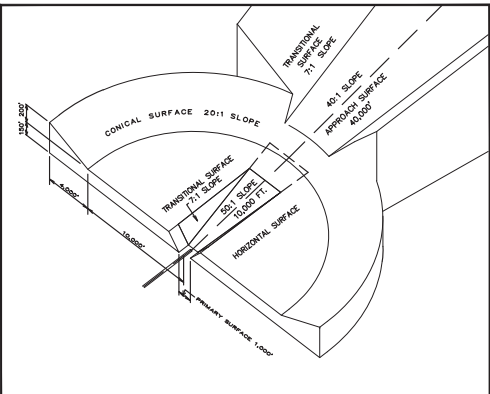

Part 77 Obstruction Table				
Obstacle ID	Description	Top Elevation	Penetration (Surface)	Disposition (See Note 4)
12-022730	RUNWAY SIGN	13	0.4 (PRIMARY)	NONE
12-022731	OL ON WIND CONE	37	24.4 (PRIMARY)	NONE
12-022732	PAPI	14	1.4 (PRIMARY)	NONE
12-022733	NAVAID	14	1.4 (PRIMARY)	NONE
12-022734	RUNWAY SIGN	13	0.4 (PRIMARY)	NONE
12-022735	POLE	19	6.4 (PRIMARY)	NONE
12-022737	RUNWAY SIGN	13	0.4 (PRIMARY)	NONE
12-022739	RUNWAY SIGN	14	1.4 (PRIMARY)	NONE
12-022740	RUNWAY SIGN	14	1.4 (PRIMARY)	NONE
12-022744	NAVAID (GS RELATED)	42	29.4 (PRIMARY)	NONE
12-022745	TOWER	43	30.4 (PRIMARY)	NONE
12-022746	OL ON WIND CONE	36	23.4 (PRIMARY)	NONE
12-022747	RUNWAY SIGN	14	1.4 (PRIMARY)	NONE
12-022748	RUNWAY SIGN	14	1.4 (PRIMARY)	NONE

C:\Users\jacobdaniels\OneDrive\Documents\2018\BMD3\AIRPORT_AIRSPACE_DRAWING_2018BMD3.dwg - LAYOUT - 12/27/2017 10:45:11 AM Plotted On: 12/27/2017 10:45:11 AM
 File: 2018BMD3.dwg - Plot Style: 2018BMD3.ctb - Plot Device: HP DesignJet 5000 Series PCL6 - Plotter: HP DesignJet 5000 Series PCL6 - Plotter Location: C:\Program Files\HP\DesignJet\5000 Series\bin\Win64\encl\hpplm64.dll
 Jacob Daniels Associates, Inc.

jda
jacobdaniels associates, inc.
121 Pearl St.
Ypsilanti, MI 48197
(734) 961-3200

RICONDO & ASSOCIATES
1000 N.W. 57th Court
Suite 920
Miami, Florida 33126-3511
(305) 260-2727

MIAMI-DADE COUNTY

NOTES:
 1. Horizontal Datum: Florida East, State Plane Coordinate System US Feet.
 2. All elevations are Above Mean Sea Level (AMSL) relative to the North American Vertical Datum of 1988 (NAVD88).
 3. Airport Elevation = 13 Feet AMSL, Horizontal Elevation: 163 Feet AMSL.
 4. Obstacles within the primary surface are fixed by function and are assumed to be installed on frangible mounts.
 5. Refer to Plan and Profile drawings for close-in obstructions. All obstacles beginning with a 12- have been extracted from FAA Digital Obstruction Files (DOF). All other obstacles are taken from ALP planimetrics and elevations are estimated.
 6. Per FAR Part-77.23(b) the following traverse ways must be increased by: 10' for an airport controlled Vehicle (Service Road (VSR), 15' for a (N)on Interstate, 17' for an (I)nterstate, and 23' for (R)ailroads. Traverse points have not been surveyed they are estimated based on the ALP topography.
 7. The topography information in the upper left-hand corner of the USGS Quad Map is not available and therefore an aerial background was inserted in this area.

Declination: 05°55'44" W (2014)
Changing: 6.0" W per Year

Revision and Description	Date	Name

DADE-COLLIER TRAINING AND TRANSITION AIRPORT
AIRPORT LAYOUT PLANS UPDATE

TNT
 Drawn by: CLJ
 Checked By: JEK
 Issue Date: DECEMBER 2017
 Sheet: 4 OF 7

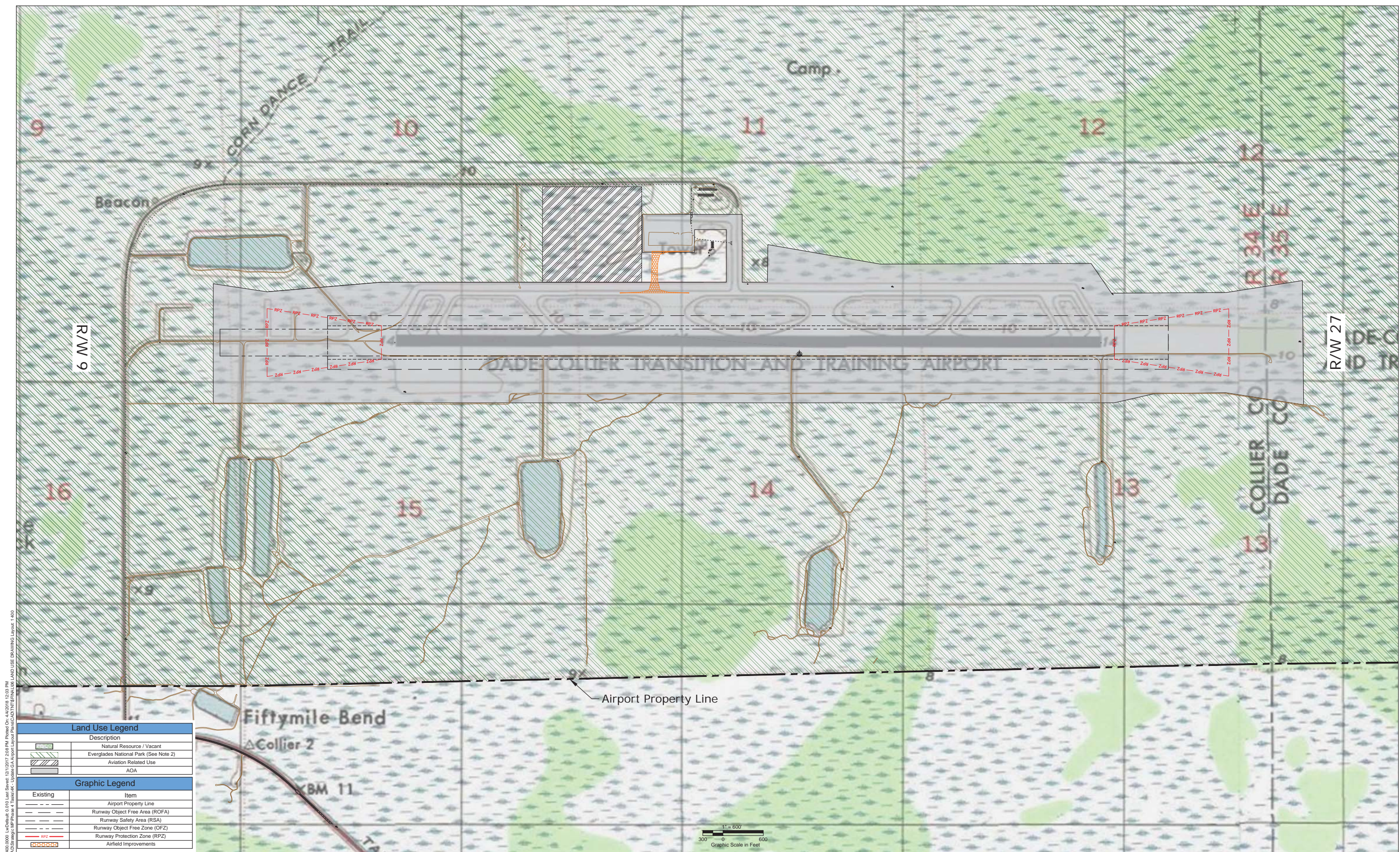

Colortable: Records: Plot Size: cd, LTS: 400,0000, LxW: 1400x1000, 0:010 Last Saved: 12/17/2017 2:08 PM Plotted On: 4/4/2018 12:03 PM
 File: \\vcc\comp\public\miamiproj\DADE\DADE-COLLIER TRANSITION AND TRAINING AIRPORT LAYOUT PLANS\LAND USE DRAWING Layout: 1:400

Land Use Legend	
Description	
	Natural Resource / Vacant
	Everglades National Park (See Note 2)
	Aviation Related Use
	AOA
Graphic Legend	
Existing	Item
	Airport Property Line
	Runway Object Free Area (ROFA)
	Runway Safety Area (RSA)
	Runway Object Free Zone (OFZ)
	Runway Protection Zone (RPZ)
	Airfield Improvements

jda
jacobsdaniels associates, llc
121 Pearl St.
Ypsilanti, MI 48197
(734) 961-3200

RICONDO & ASSOCIATES
1000 N.W. 57th Court
Suite 920
Miami, Florida 33158-2511
(305) 260-2727

MIAMI-DADE COUNTY

NOTES:

- This composite map illustrates information contained in the official Miami-Dade zoning district maps and reflects existing land uses.
- Property managed and operated by the Florida Game and Freshwater Fish Commission.

Declination: 05°55'44" W (2014)
Changing: 6.0" W per Year

Revision and Description	Date	Name

LAND USE DRAWING

DADE-COLLIER TRANSITION AND TRAINING AIRPORT
AIRPORT LAYOUT PLANS UPDATE

TNT

Drawn by: *CLJ*

Checked By: *JEK*

Issue Date: DECEMBER 2017

Sheet: **6** OF **7**

Appendix C FAA Approval Letter for MDAD SMP Study GA Forecast Report

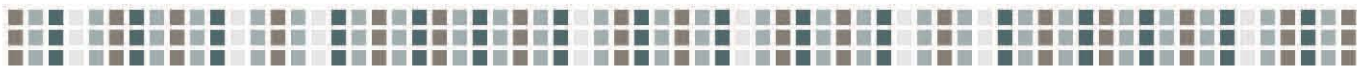



U.S. Department
of Transportation
**Federal Aviation
Administration**

ORLANDO AIRPORTS DISTRICT OFFICE

5950 Hazeltine National Dr., Suite 400

Orlando, Florida 32822-5003

Phone: (407) 812-6331 Fax: (407) 812-6978

August 6, 2012

Mr. Jose A. Ramos, R.A.
Division Director
Aviation Planning, Land Use, and Grants
Miami-Dade Aviation Department
Miami International Airport
P.O. Box 592075
Miami, Florida 33159

Dear Mr. Ramos,

RE: Miami Dade Aviation Department
Strategic Airport Master Planning Study
Approval of General Aviation Activity Forecasts

This letter responds to your consultant's July 27, 2012 transmission of the "Strategic Airport Master Planning Study General Aviation Activity Forecasts" dated June 2012. While the forecasts depicted in Table 5, on page 44 of the report, as attached, are not consistent with the 2011 Federal Aviation Administration (FAA) Terminal Area Forecasts (TAF,) the methods and assumptions used in preparing these forecasts are found to be reasonable. In addition, the overall general aviation demand forecast for the Miami Dade area, as shown in your report, is consistent with the sum of the general aviation demand the 2011 TAF presents for the individual Miami Dade airports. Therefore, we approve the forecasts to be used in your on-going master planning efforts.

If you have any questions, please feel free to contact me at (407) 812-6331, ext. 122.

Sincerely,

ORIGINAL SIGNED BY

Rebecca R. Henry
Planning Specialist

cc: Paul Devoti, APP-400
Remy Lucette, Ricondo & Associates, Inc.